



## Central Inverter

# SUNNY CENTRAL 200 / 250 / 350 / 500 / 560

### User Manual





# Table of Contents

<b>1</b>	<b>Notes on this Manual.</b> . . . . .	<b>7</b>
1.1	Area of validity . . . . .	7
1.2	Target Group . . . . .	7
1.3	Additional Information . . . . .	7
1.4	Symbols Used . . . . .	8
<b>2</b>	<b>Safety</b> . . . . .	<b>9</b>
2.1	Appropriate Usage . . . . .	9
2.2	Safety Instructions . . . . .	10
2.3	Identifying the Sunny Central . . . . .	11
2.4	Operating Modes . . . . .	12
<b>3</b>	<b>Grid Security Management.</b> . . . . .	<b>14</b>
3.1	What are the requirements? . . . . .	14
3.2	Active Power Limitation . . . . .	14
3.3	The Solution from SMA Solar Technology . . . . .	15
<b>4</b>	<b>Control Elements</b> . . . . .	<b>16</b>
4.1	Overview . . . . .	16
4.2	Sunny Central . . . . .	17
4.2.1	Indicator Lights . . . . .	17
4.2.2	Key switch . . . . .	17
4.2.3	AC Main Switch . . . . .	17
4.2.4	Emergency Stop . . . . .	18
4.3	Sunny Central Control . . . . .	19
4.3.1	Functions of the Control Buttons . . . . .	20
4.3.2	Description of the Display Symbols. . . . .	21
<b>5</b>	<b>Menu</b> . . . . .	<b>22</b>
5.1	Display Messages During Operation . . . . .	22

5.2	Menu Overview . . . . .	22
5.2.1	Operating data . . . . .	22
5.2.2	Spot Values . . . . .	23
5.2.3	Long-Term Data . . . . .	24
5.2.4	Device Set-up . . . . .	24
5.3	Adjusting the Display Contrast . . . . .	26
5.4	Setting the Language . . . . .	26
5.5	Changing the Date and Time . . . . .	26
5.6	Enter Password . . . . .	27
5.7	Display Firmware Version . . . . .	27
5.8	Deleting the Daily Values of the Energy Yield. . . . .	28
<b>6</b>	<b>Measuring Channels . . . . .</b>	<b>29</b>
6.1	Adding Further Measurement Channels . . . . .	31
6.2	Resetting the Display of Measurement Channels to the Factory Setting. . . . .	31
6.3	Retrieving Measurement Data . . . . .	32
6.3.1	Retrieving Measurement Data at the Sunny Central Control . . . . .	32
6.3.2	Retrieving Measurement Data via Sunny Data Control . . . . .	32
6.4	Deleting Measurement Data. . . . .	33
<b>7</b>	<b>Parameters . . . . .</b>	<b>34</b>
7.1	Description of the Parameter Functions. . . . .	35
7.2	Default Parameter Settings . . . . .	38
7.3	Changing Parameters . . . . .	39
7.4	Resetting Parameters. . . . .	40
7.5	Saving Parameters . . . . .	40
<b>8</b>	<b>Sending Data . . . . .</b>	<b>41</b>
8.1	Selecting Remote Info . . . . .	41
8.2	Activating Email Reports . . . . .	42

8.3	Selecting Report Types to Send . . . . .	42
8.3.1	Daily Report "System Info" . . . . .	44
8.3.2	Hourly Report "Errors, Warnings and Events" . . . . .	45
8.4	Entering or Changing an Email Address . . . . .	46
8.5	Sending a Test Report . . . . .	47
<b>9</b>	<b>Analog Inputs . . . . .</b>	<b>48</b>
9.1	Detecting External Sensors . . . . .	49
9.2	Calculating Gain and Offset . . . . .	50
9.3	Configuring External Sensors . . . . .	52
9.3.1	ExtSolIrr and ExtGloIrr . . . . .	52
9.3.2	Displaying Sensor Values . . . . .	53
9.4	Configuring External Messages . . . . .	53
9.4.1	Setting ExtAlarm . . . . .	53
9.4.2	Activating TmpExt C . . . . .	54
<b>10</b>	<b>Active Power Limitation . . . . .</b>	<b>55</b>
10.1	Procedure for Setting Active Power Limitation . . . . .	55
10.2	Active Power Limitation via Grid Frequency . . . . .	57
<b>11</b>	<b>Grid Monitoring . . . . .</b>	<b>58</b>
11.1	Grid Connection after Fault Clearance . . . . .	58
11.2	Behavior of Grid Limits over Time when Breaches Occur . . . . .	59
11.3	Setting the Medium-Voltage Level (applicable only to HE devices) . . . . .	60
11.4	Disconnection Protection Ramp (DCRmp) . . . . .	60
<b>12</b>	<b>External Grid Monitoring Relay (optional) . . . . .</b>	<b>61</b>
12.1	Overview of the Display and Control Elements . . . . .	62
12.2	Display Messages . . . . .	63
12.3	Configuration . . . . .	64
12.3.1	Changing from Automatic Mode to Configuration Mode . . . . .	64

12.3.2	Access to Configuration .....	65
12.3.3	Parameters .....	66
12.3.4	Monitoring .....	66
12.4	Alarm Messages / Dealing with Errors.....	72
12.4.1	Clear Alarm Signal .....	72
12.4.2	Interface .....	72
<b>13</b>	<b>Islanding Detection (Anti-Islanding) .....</b>	<b>73</b>
<b>14</b>	<b>Sunny Team (optional) .....</b>	<b>74</b>
14.1	Identification of Manager Device and Team Device .....	74
14.2	Display of Team Mode on the Sunny Central.....	74
14.3	Operating States of Sunny Team .....	75
14.4	Team Status.....	76
14.5	Team Mode Interrupted .....	77
14.6	Disable Team Mode .....	78
14.7	Enable Team Mode .....	79
<b>15</b>	<b>Troubleshooting and Problem Solving.....</b>	<b>80</b>
15.1	Fault Diagnosis .....	81
15.1.1	Categories of Faults and Warnings .....	81
15.1.2	Types of Faults and Warnings.....	81
15.1.3	Warnings .....	82
15.1.4	Faults.....	86
15.1.5	Events .....	93
15.2	Clearing Errors .....	93
<b>16</b>	<b>Contact .....</b>	<b>94</b>

# 1 Notes on this Manual

This manual describes the operation and troubleshooting of the Sunny Central with the aid of Sunny Central Control. Store all accompanying documentation in the direct vicinity of the Sunny Central. This must be available to operators and maintenance staff at all times

## 1.1 Area of validity

This manual applies to the following device types with a Sunny Central Control 03 from firmware version 2.04.

- SC 100LV
- SC 125LV
- SC 150
- SC 200HE
- SC 200
- SC 250HE
- SC 250
- SC 350HE
- SC 350
- SC 500HE
- SC 560HE

## 1.2 Target Group

This manual is for the use of installers and operators of PV plants equipped with a Sunny Central.

## 1.3 Additional Information





All manuals for the Sunny Central as well as for the installed components must be stored together with the system documentation and must be accessible at all times. The documents listed below are included in the delivery of your Sunny Central.

The following information is contained in these documents.

<b>Installation guide</b>	Setup and installation of the Sunny Central
<b>User Manual</b>	How to operate the Sunny Central and Sunny Central Control
<b>Maintenance Manual</b>	Maintenance of the Sunny Central
<b>Wiring diagrams</b>	Wiring diagrams of the Sunny Central
<b>Accessory Documentation</b>	The documentation for optional accessories or optional equipment for the Sunny Central (e.g. GFDI) can be found online at <a href="http://www.SMA.de/en">www.SMA.de/en</a> .

## 1.4 Symbols Used

The following types of safety precautions and general information are used in this manual:

	<b>DANGER!</b>
DANGER indicates a hazardous situation which, if not avoided, will result in death or serious injury.	
	<b>WARNING!</b>
WARNING indicates a hazardous situation which, if not avoided, could result in death or serious injury.	
	<b>CAUTION!</b>
CAUTION indicates a hazardous situation which, if not avoided, could result in minor or moderate injury.	
	<b>NOTICE!</b>
NOTICE indicates a situation which, if not avoided, could result in property damage.	
	<b>Information</b>
Information provides tips that are valuable for the optimal installation and operation of your product.	



## 2 Safety

### 2.1 Appropriate Usage

The Sunny Central is a PV inverter. It allows photovoltaic solar energy from PV modules to be converted and fed into a medium-voltage grid.

The Sunny Central models SC 100LV, SC 125LV, SC 150, SC 200HE, SC 200, SC 250HE, SC 250, SC 350HE, SC 350, SC 500HE and SC 560HE are equipped with the new grid security management function. Further information on grid security management is provided in Section 3 "Grid Security Management" (page 14).

#### Principle of a grid-connected PV system with a Sunny Central

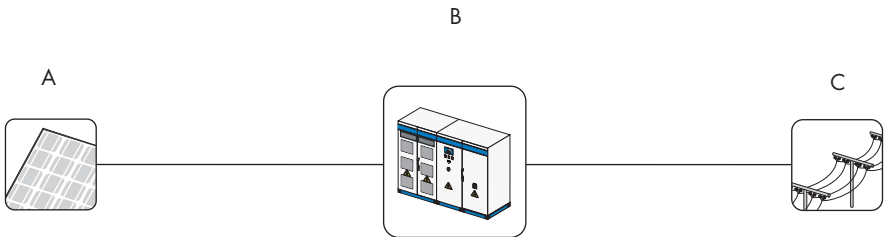

Object	Description
A	PV Generator
B	Sunny Central
C	Public grid

#### Sunny Central

The Sunny Central is equipped with a low-voltage transformer, and feeds into the low-voltage grid.

#### Sunny Central HE

The Sunny Central HE does not have its own low-voltage transformer. It requires an adapted external medium-voltage transformer via which it can feed into the grid.

#### Sunny Central LV

The Sunny Central LV feeds into the low-voltage grid. It is suitable for the connection of PV generators with low voltage.

#### Sunny Central MV

The MV stations are medium-voltage stations. In an MV station, two Sunny Central HE devices feed into the medium-voltage grid via a shared medium-voltage transformer.

## 2.2 Safety Instructions

**DANGER!**

**Contact with live components of the low voltage grid can be lethal! Death or serious burns.**

- Do not touch live components of the Sunny Central or the low-voltage grid.
- All safety precautions regarding the low-voltage grid must be observed.

**DANGER!**

**Danger to life due to high voltages in the Sunny Central! Death or serious burns.**

- Any work on the Sunny Central may be carried out by qualified electricians only.
- Work on the Sunny Central must only be carried out as described in this manual.
- Comply with all the listed safety instructions.
- All the safety instructions in the Sunny Central installation guide must be observed.

**DANGER!**

**Danger to life due to damage to the Sunny Central. Death or serious burns.**

Damage to the Sunny Central, e.g. defective cables, or a damaged enclosure, can lead to death by electric shock or fire.

- Only operate the Sunny Central when it is in a technically faultless and safe condition.
- Never operate a damaged Sunny Central.
- Check the Sunny Central regularly for visible damage.
- Regularly ensure that all external safety features are freely accessible at all times, and that they function correctly.

## 2.3 Identifying the Sunny Central

Identify the Sunny Central by the serial number and the device type on the type plate. The type label is situated on the inside of the door.

The serial number (A) is also located on the front side of the Sunny Central.

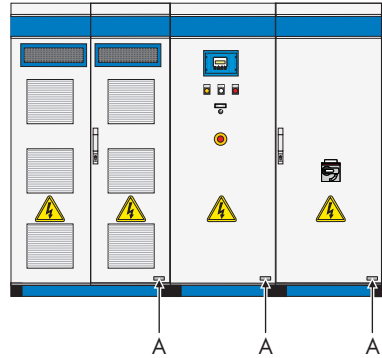

## 2.4 Operating Modes

After switch-on, the Sunny Central runs through the different modes illustrated below. When switched off, the Sunny Central is in the "Stop" mode. By turning the key switch, the Sunny Central goes into the "Wait" mode.

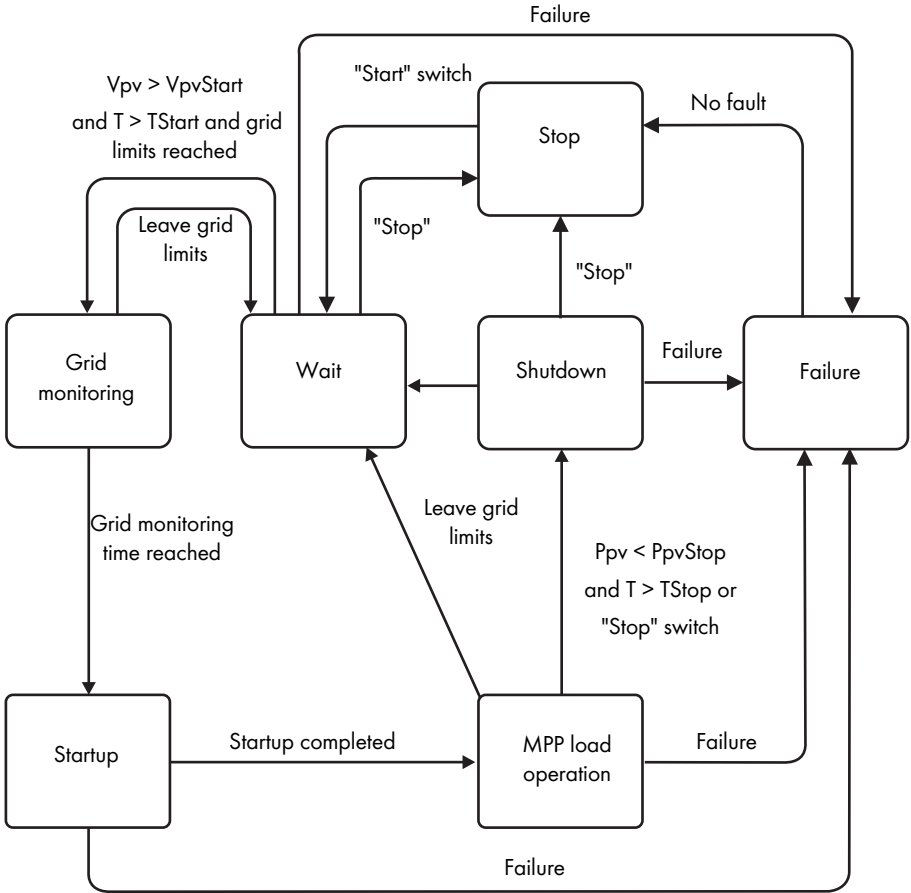

Operating mode	Explanation
Stop	The Sunny Central is switched off. The Sunny Central remains in this condition until the key switch is turned to "Start".
Wait	<p>If the key switch is set to "Start", the Sunny Central goes into to the "Wait" mode.</p> <p>The start voltage "VpvStart" must be adjusted to conform to the PV generator connected to the Sunny Central. Check and adjust the start voltage as necessary.</p> <p>If the input voltage is below the set start voltage "VpvStart", the Sunny Central remains in "Wait" mode. The value for "VpvStart" is shown in the display of Sunny Central Control.</p> <p>If the input voltage is higher than the start voltage "VpvStart", the Sunny Central waits until the time defined in the parameter "TStart" has elapsed. If the input voltage has not fallen below the start voltage "VpvStart" during this period, the Sunny Central checks whether there is connection to the AC grid. If there is a valid AC grid connection, the AC contactor closes and the Sunny Central transfers to grid monitoring.</p>
Grid Monitoring	The grid is monitored for adherence to grid limits for the monitoring time "GriGrdMonTm". If the grid limits are not exceeded during this time, the Sunny Central goes into the "Startup" mode.
Startup	After completing grid monitoring, the Sunny Central navigates to its first operating point and commences grid feed.
MPP load operation	In MPP operation the Sunny Central feeds power to the grid and operates continuously at the maximum power point (MPP).
Shutdown	<p>The Sunny Central shuts down (switches off) in the following cases:</p> <ul style="list-style-type: none"> <li>• The power measured during the time interval "TStop" is less than "PpvStop".</li> <li>• A failure has occurred which necessitates shutdown of the Sunny Central.</li> <li>• The key switch is set to "Stop".</li> </ul>
Failure	If a fault occurs during operation, the Sunny Central shuts down and the Sunny Central Control displays the fault. You will find a list of faults in section 15 "Troubleshooting and Problem Solving" (page 80).

## 3 Grid Security Management

### 3.1 What are the requirements?

In Germany, PV systems with an installed capacity of more than 100 kWp must participate in feed and grid security management. First and foremost, the utility operator must be able to limit the power of the PV system by remote control, and temporarily reduce it to zero in critical cases. Relevant control commands from the utility operator must therefore be transmitted quickly and reliably to the Sunny Central.

#### The requirements in detail

- Reception of the setpoint via a centralized ripple control signal receiver with 2 or 4 relays.
- Limitation of the feed-in power in 4 configurable stages (for example, 0 % / 30 % / 60 % / 100 % of the agreed installed active power  $P_{AV}$ ).
- Setting of the required setpoint in less than a minute.

### 3.2 Active Power Limitation

Under certain circumstances, the grid operator is entitled to dictate a temporary limitation of feed-in power or to implement a system shutdown. According to the Medium-Voltage Directive, generator systems must be able to reduce their active power in stages of no more than 10 % of the agreed installed active power  $P_{AV}$ . However, the four staged reductions of 100 %, 60 %, 30 % and 0 % of the connected system power have become standard practice.

### 3.3 The Solution from SMA Solar Technology

With the Power Reducer Box it is possible to implement active power limitation in accordance with the requirements of grid security management (GSM) for a PV system.

To do this, four digital states (e.g. of a radio ripple control receiver) can be imported via the the Power Reducer Box, thus enabling the Sunny Central to be set according to the specifications of the utility operator.

The four input ports are freely configurable via the integrated web interface. If a signal from the radio ripple control receiver is present, the Power Reducer Box analyzes the signal and relays an instruction via the Ethernet network to the registered Sunny WebBox devices.

Activated Sunny WebBox devices transfer the instruction to the connected Sunny Central.

Events are recorded onto the internal memory of the Power Reducer Box. In addition, it is possible to write events onto an SD card or download events via the web interface.

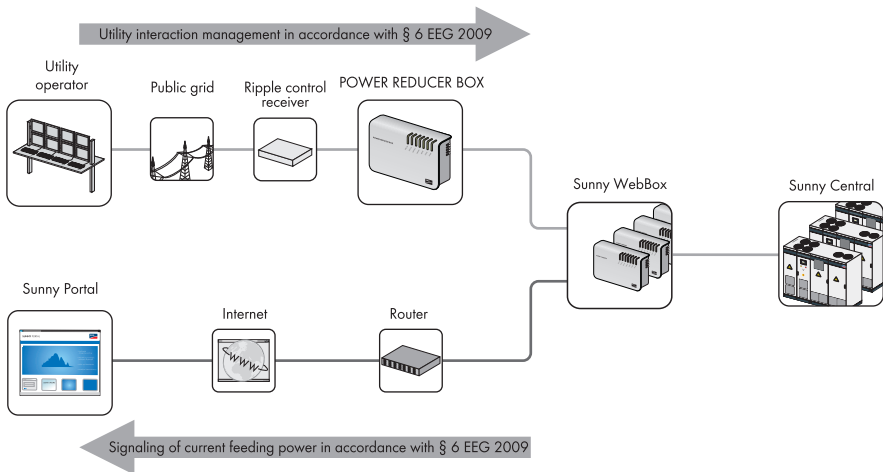

Besides the Power Reducer Box, there are two further options for meeting the requirement of grid security management. These are 1) reception of the signals via an analog input on the Sunny Central and 2) manual setting of default values via parameters.

How to implement these options is described in this manual.

## 4 Control Elements

### 4.1 Overview

The following diagram shows the different control elements, based on the example of a Sunny Central 250.

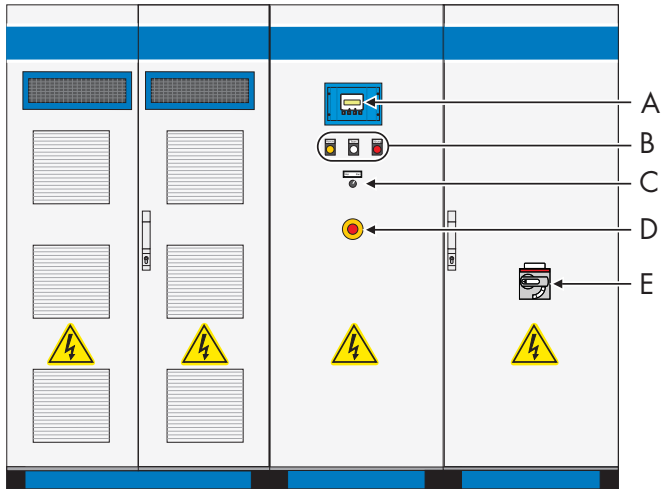

Object	Description
A	Sunny Central Control
B	Indicator light (disturbance, warning, Sunny Team)
C	Key switch
D	Emergency shut-off with key
E	AC Main Switch



## 4.2 Sunny Central

### 4.2.1 Indicator Lights

There are 2 indicator lights at the front of the Sunny Central. If an error occurs, these indicator lights indicate the type of failure.

#### Meaning of the colors

- Yellow:** The Sunny Central is in "Alert" status. The Sunny Central does not switch off. Check the system. Once the error is no longer active, the fault indication is automatically reset.
- Red:** The Sunny Central is in "Fault" status. If the Sunny Central has detected a fault, it will shut down. Once the error has been rectified and cleared, it will resume operation. For more information see Section 15.1.2 "Types of Faults and Warnings" (page 81).

### 4.2.2 Key switch

The key switch is used to switch the Sunny Central on and off. After turning the switch to the "Start" position, the Sunny Central switches from the "Stop" mode to the "Wait" mode. Given sufficient irradiation and a valid grid, the Sunny Central goes into grid feeding operation. If the irradiation, and thus the input voltage, are too low, the Sunny Central remains in "Wait" mode.

When the key switch is turned to "Stop", the DC main switch is automatically switched off by a motor drive.

### 4.2.3 AC Main Switch

**NOTICE!**

**Improper use of the AC main switch may cause damage to the Sunny Central.**

The components of the Sunny Central are subject to considerable stress if the AC main switch is actuated under load. Frequent use of the AC main switch can cause stress-related damage to individual components.

- Switch off the Sunny Central with the key switch.
- Operate the AC main switch.

The AC main switch enables you to disconnect the Sunny Central from the grid on the AC side.

## 4.2.4 Emergency Stop



### NOTICE!

#### **Improper use of the emergency shut-off switch may cause damage to the Sunny Central.**

The components of the Sunny Central are subject to considerable stress if the emergency shut-off switch is actuated under load. Frequent use of the emergency shut-off switch can cause stress-related damage to individual components.

- Only use the emergency shut-off switch in an emergency.
- Switch off the Sunny Central with the key switch.

The emergency shut-off switch immediately disconnects the Sunny Central from the grid and the PV generator, thus putting the Sunny Central in a safe state.

By pressing the emergency shut-off switch, the device is locked in the "Off" position. The emergency shut-off switch can only be deactivated with the appropriate key. In addition, the activation of the emergency shut-off switch must be cleared using Sunny Central Control or Sunny Data Control.

You can install an external emergency shut-off switch on each Sunny Central or connect several Sunny Centrals via a shared emergency shut-off switch.

### 4.3 Sunny Central Control

Sunny Central settings can be adjusted by means of the Sunny Central Control. The functions performed by Sunny Central Control can be summarized as follows:

- Control of the Sunny Central operation
- Display of current measured values
- Changing the parameters of the Sunny Central
- Maximum power point (MPP) tracking
- Collection and archiving of measurement data
- Remote access capability with NET Piggy-Back
- Connection of external sensors

The Sunny Central Control is mounted at eye level on the Sunny Central. The Sunny Central Control is operated by means of four control buttons. These buttons are situated beneath the 4-line display.

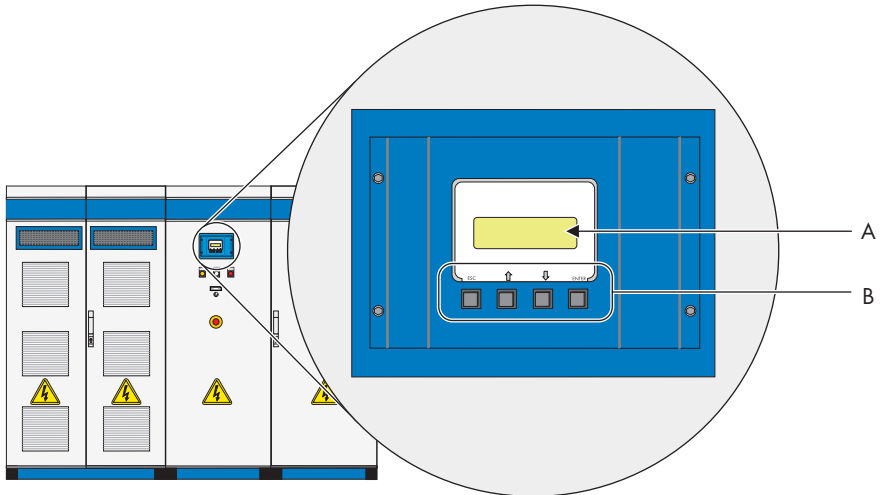

Object	Description
A	4-line display
B	Control buttons

### 4.3.1 Functions of the Control Buttons

The control buttons have several functions. The buttons and their functions are described in the following table.

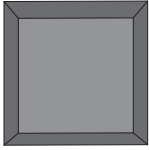
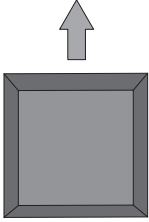
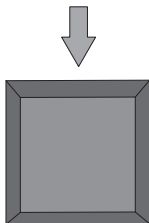
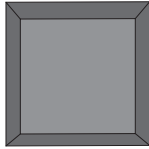
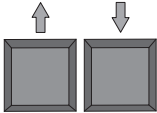
Button	Description / Function
<p style="text-align: center;">ESC</p> 	<p>ESC</p> <ul style="list-style-type: none"> <li>• Cancels / exits function</li> <li>• Answers questions with "No"</li> <li>• Returns to the previous menu</li> <li>• Changes from the standard view to the main menu</li> </ul>
	<p>Upward arrow</p> <ul style="list-style-type: none"> <li>• Moves to line above</li> <li>• Increases value</li> </ul>
	<p>Downward arrow</p> <ul style="list-style-type: none"> <li>• Moves to line below</li> <li>• Decreases value</li> </ul>
<p style="text-align: center;">ENTER</p> 	<p>ENTER</p> <ul style="list-style-type: none"> <li>• Selects a function from the menu</li> <li>• Selects a value</li> <li>• Confirms changes</li> <li>• Answers questions with "Yes"</li> </ul>
	<p>Upward arrow + downward arrow</p> <ul style="list-style-type: none"> <li>• Returns to standard view</li> </ul>

### 4.3.2 Description of the Display Symbols

The Sunny Central Control display has four lines. It uses various display symbols, which are explained in the following table.

Symbol	Description
↓	There are more display lines below
↑	There are more display lines above
⚡	There are more display lines above and below
→	Appears to the left of the currently selected line. Press [ ↑ ] or [ ↓ ] to move to another line.
→ (lit)	Appears to the left of a value which can be changed.
→ (blinking)	If, for example, a parameter has been changed, the arrow to the left of the active line blinks.
⌂	The Sunny Central Control is loading the next menu or saving data.

## 5 Menu

### 5.1 Display Messages During Operation

After the Sunny Central has been switched on, the Sunny Central Control initializes. Initialization involves a sequence of three display messages.

After initialization the Sunny Central displays the measured values and spot values shown to the right.

You can switch between the three views with the buttons [ ↑ ], [ ↓ ] or [ENTER]. If a warning or fault is reported, the display will alternate between the active standard view and the error with the highest priority.

```

Mode           MPP
Pac            85.7kW
E-Today       357.5kWh
E-Total       12512.3kWh
    
```

```

Mode           MPP
Ppv            89.27kW
Upv            557V
Ipv            160.26A
    
```

```

Mode           MPP
fac            50.04Hz
Uac            230.51V
Iac            124.04A
    
```

### 5.2 Menu Overview

#### 5.2.1 Operating data

<b>Faults</b>	Current Faults SC	Quit Function
	BFR Error	
	Stack Failure	
	Err Meas. DC	
<b>Plant Status</b>	State	
	Inverter Status	
<b>Energy Yield</b>	E-Total	
	E-Today	
<b>Data files</b>	Meas. Interval	
	Daily Values	
	Meas. Channels	

<b>Other</b>	h-On
	Working Time
	Startup counter
	Fault counter
	Alert counter

## 5.2.2 Spot Values

<b>PV</b>	Ppv
	Vpv
	Ipv
<b>Grid</b>	Pac
	Qac
	Sac
	Fac
	Iac
	Vac L1-L2
	Vac L2-L3
Vac L3-L1	
<b>Red.effect.pow.</b>	P-WSpt
	P-WModFailStt
	P-WModStt
<b>Outp.react.pow. (displayed but not supported)</b>	
<b>Grid decoupling</b>	GriGrdStt
<b>Other</b>	T-Heat Sink C
	Mppsearchcount
	Team status
	R-Insul
	TmpInt C
	TmpExt C
	ExtSolP
	ExtSolQ (displayed but not supported)
	ExtSolIrr
	ExtGloIrr

### 5.2.3 Long-Term Data

<b>Long-Term Data</b>	Meas. Chn.
	Energy Yield
	Plant Status
	Faults

### 5.2.4 Device Set-up

<b>Password</b>			
<b>System</b>	Language		
	Date/Time		
	Inverter Type		
	Firmware		
	BFR_SW_Vers.		
<b>Parameters</b>	Param. Function		
	Red.effect.pow.	P-WMod, P-W, P-WNom, Plimit, Pmax, Smax	
	Outp.react.pow. (displayed but not supported)		
	Grid decoupling	Voltage	VRtg, VCtlhhLim, VCtlhhLimTm, VCtlhLim, VCtlhLimTm, VCtlLim, VCtlLimTm, VCtllLim, VCtllLimTm
		Grid frequency	HzRtg, HzCtllhLim, HzCtllhLimTm, VCtlhLim, VCtlhLimTm, VCtlLim, VCtllLimTm, VCtllLim, VCtllLimTm, HzCtllMin, HzCtllMinTm
	Grid connection	GriGrdMonTm, VCtlOpMinNom, VCtlOpMaxNom, HzCtllOpMin, HzCtllOpMax	
	Mpp Limit Val.	UmppMin, dUreference, PsearchMpp, TsearchMpp	
	Mpp Tracking	dUtrack, TcheckMpp, Mpp Factor, TrackCnt	
	Start requiremt.	Operating Mode, VpvStart, Tstart	
	Shut-down requ.	PpvStop, Tstop	
	Grid Monitor.	PpvMinCheck	
	Other	E-Total Offset, TMax. cabinet, TMin. cabinet, Team function, P-Next Team, P-Prv. Team, Tau-FP, Test.feed.unit, Date availab., TmpDrtStopMod	



<b>Interfaces</b>	Communication	COM1:SMUs	Medium, Baud rate, Protocol	
		COM2: Inverter	Medium, Baud rate, Protocol, Registration, Detection, Parameters, Measured values	
		COM3: PC	Medium, Baud rate, Protocol	
	Analog In	ExtSolP, R-Insul, ExtSolIrr, ExtGloIrr, ExtAlarm, ExtSolQ (displayed but not supported), TmpExt C		
	Digital In	Digital Input 1 - 8		
	Digital Out	+Diag Ext+24V, +Diag DOut, Dig. Output 1 - 8		
<b>Data archives</b>	Data Recording			
	Meas. Interval			
	Max. Storage			
	Chan. Select.			
<b>SMUs</b>	Devices	Registration, Detection, Parameters, Measured Values		
	Parameters	regist. SMUs, Error Report Time, Polling Time, SMU_Overnight Shutdown, SMU_Theft, Tolerance Grp1 - 3		
	Measured Values	mean value Grp1 - 3		
	Failure	Actual Failures, Hist. failures		
<b>NET/EMAIL</b>	NET	KO_NET, KO_NET-ETH IP, NET-ETH SNET, KO_NET-ETH PVSN, NET-ETH GW, NET-ETH DNS		
	Remote-Info	EMAIL		
		Events	Plant info, warnings, errors, daily report at	
		Recipient	Company/Name, EMAIL TO, EMAIL CC1, EMAIL CC2	
		Sender	Plant Name, EMAIL FROM	
		ISP Account	ISP Phone No., ISP User, ISP Pass	
		SMTP Account	SMTP Server, SMTP User, SMTP Pass, Default	
		Test Report		

### 5.3 Adjusting the Display Contrast

You can adjust the display contrast in any menu. You need to use a two-button combination to increase or decrease the contrast.

Button combination	Function
[ESC] + [ ↑ ]	Increases the contrast.
[ESC] + [ ↓ ]	Decreases the contrast.

### 5.4 Setting the Language

You can choose between the languages German, English and Spanish. If you wish to change the language setting, proceed as follows:

1. Select „Device Set-up > System > Language“.

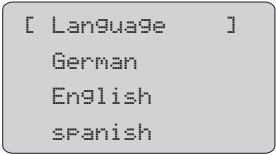

```
[ Language ]
German
English
spanish
```

2. To select the required language press [ENTER] twice.
  - The required language is now set.

### 5.5 Changing the Date and Time

The Sunny Central Control's default settings for date and time correspond to the Central European time zone. In order to change the date or the time proceed as follows:

1. Select "Device Set-up > System > Date/Time".



```
[ Date/Time ]
20/05/2008
13:47
```

2. Click on the date.
3. Set the required date (day, month and year ) with the [ ↑ ] or [ ↓ ] buttons and confirm each value setting with [ENTER].
4. Press [ENTER] twice to confirm the date as a whole.
  - The required date has been set.
5. Click on the time.
6. Set the required time (hours and minutes) with the [ ↑ ] or [ ↓ ] buttons and confirm each value setting with [ENTER].
7. Press [ENTER] twice to confirm the time as a whole.
  - The required time has been set.
  - Date and time have now been changed.

## 5.6 Enter Password

Safety-relevant Sunny Central parameters can only be adjusted after entering a password. You can obtain a password from our Serviceline (see Section 16 "Contact" (page 94)).

Proceed as follows to enter the password:

1. Select "Device Set-up > Password".



2. Enter the password with the [ ↑ ] or [ ↓ ] buttons and confirm the set value with [ENTER].
  - After confirmation, the entered values are displayed as a row of asterisks.
  - The Sunny Central Control beeps 3 times if the correct password has been entered. If the password is incorrect, the Sunny Central Control beeps once.



### Locking the Sunny Central Control

You can lock the Sunny Central Control under "Device Set-up > Password", by entering an incorrect password, or no password.

Password protection will automatically resume at midnight, or after a restart of Sunny Central Control.

## 5.7 Display Firmware Version

You can view the firmware version on Sunny Central Control under "Device Set-up > System > Firmware".

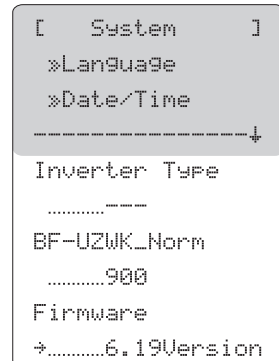

## 5.8 Deleting the Daily Values of the Energy Yield

The daily values of the energy yield can be displayed on the Sunny Central Control under "Long-Term Data > Energy Yield". The daily values are sorted according to the month. A list of daily energy yields is displayed upon selecting the required month by pressing [ENTER].

You can delete the daily energy yield values as described below:

1. Select "Device Set-up > Parameters > Param.-Function".

The display blinks.

```
[ Parameters ]
Param.-Function
.....
-----↓
```

2. Select "Del Daily Value" with the [ ↓ ] button and confirm by pressing [ENTER].

The daily energy yield values have now been reset to the factory setting.

```
[ Parameters ]
Param.-Function
Del Daily Value
-----↓
```

## 6 Measuring Channels

You can use the Sunny Central Control to display different measurement channels. To do this, proceed as described in Section 6.3 "Retrieving Measurement Data" (page 32).

All the measurement channels are described in the following table. The measurement channels marked with an \* are preset in the factory and are standardly displayed in the Sunny Central Control under "Long-Term Data > Meas. Chn. > SC...SCXXX".

Measuring channel	Description
+Diag DOut	The measurement channel can only be seen after the installer password has been entered. Status of the digital output "+Diag DOut" (Status: Fault, Okay)
+Diag Ext+24V	The measurement channel can only be seen after the installer password has been entered. Status of the digital output "+Diag Ext+24V" (Status: Fault, Okay)
Startup counter	Counter for the number of times the system has started up.
Digital Input 1	Status of digital inputs 1 to 8
Digital Input 2	
Digital Input 3	
Digital Input 4	
Digital Input 5	
Digital Input 6	
Digital Input 7	
Digital Input 8	
E-Today	Energy which the Sunny Central has fed into the grid today. This is the energy generated from the time the Sunny Central starts operating in the morning to the moment of the reading.
Error *	Error of the Sunny Central.
E-Total	Total energy which the Sunny Central has fed into the grid during its operating time.
ExtGloIrr	Analog input - external pyranometer (optional)
ExtSolIrr	Analog input - external irradiation sensor (optional)
ExtAlarm	Analog input - external temperature sensor (optional)
ExtSolP	Analog input - external setpoint specification of active power
ExtSolQ	This measuring channel is displayed but not supported.
Fac	Grid frequency
FI Code	Response code of the NET Piggy-Back
FI Status	Status of the connection setup to the NET Piggy-Back
h-On *	Total number of operating hours
h-Total *	Total number of operation hours with grid feed

Measuring channel	Description
Iac	Grid output current
Ipv *	DC input current
Comm.fault SMU	Faulty communication with Sunny String-Monitor No.
Meas. Data	Counter for the number of times an entry is saved in the circular buffer.
Mean value Grp1	Mean value of the string currents of Sunny String-Monitor group 1 to Sunny String-Monitor group 3
Mean value Grp2	
Mean value Grp3	
Mode *	Sunny Central operating mode (e.g. MPP)
Mppsearchcount	Counter for the number of times the system changed to MPP Search.
Pac *	Grid output power of the des Sunny Central
Pac smoothed	Smoothed feed-in power.
Ppv	DC input power of the Sunny Central
P-WModStt *	Display of the currently effective active power limit.
Qac *	Reactive power
Reg. SMUs	Number of registered Sunny String-Monitors
R-Insul *	Isolation resistance
SMU Warncode	The channel "SMU Warncode" displays a number code "xxyy" where xx: denotes the number of the faulty Sunny String-Monitor (1 to 40) and yy the error number 01 - 08: channel number for error in string current monitoring; 09 - 10: error in signaling contact monitoring
Fault counter	Counter for the number of times a fault has occurred.
Team Status	Status of Sunny Team For more information, refer to Section 14.4 "Team Status" (page 76).
Cooler Temp. *	Temperature of the heat sink
TmpExt C *	Analog input of the external temperature sensor (optional)
Tmplnt C	Analog input of the internal temperature sensor (standard)
TStart Reverse	Time remaining until the system starts up.
TWait Reverse	Time remaining until the next plant start-up attempt
Vac L1-L2 *	Grid output voltage L1-L2
Vac L2-L3	Grid output voltage L2-L3
Vac L3-L1	Grid output voltage L3-L1
Vpv *	DC input voltage of the Sunny Central
Vpv0 *	Open-circuit voltage of the PV plant
VpvSet	DC setpoint input voltage
Warn. counter	Counter for the number of times a warning has occurred.

## 6.1 Adding Further Measurement Channels

You can add further channels to the standard 14 measurement channels. To do this, proceed as follows:

1. Select "Device Set-up > Data Archives > Chan. Select. > SC...SCXXX".

- The Sunny Central Control displays all measurement channels. The measurement channels already displayed in the menu "Long-Term Data > Meas. Chn. > SC...SCXXX" are marked with a dot.

```
[SC:C.Selection]
·E-heute
·E-Total
·State
```

2. Select the measurement channel to be added with the [ ↓ ] button and confirm with [ENTER].
  - A dot now appears in front of the selected measurement channel.
3. When exiting the menu, confirm changes with [ENTER].
  - Further measurement channels have been added. To call up the measurement data, follow the steps in Section 6.3 "Retrieving Measurement Data" (page 32).

## 6.2 Resetting the Display of Measurement Channels to the Factory Setting

The Sunny Central Control displays 14 measurement channels as standard. If you have added extra channels to the display, it is possible to reset the display back to default. To do this, proceed as follows:

1. Select "Device Set-up > Parameters > Param. Function".

- The display blinks.

```
[ Parameters ]
Param.-Function
.....
-----↓
```

2. Select "default chan.".

- The display stops blinking.

```
[ Parameters ]
Param.-Function
default chan.
-----↓
```

3. Press [ENTER].

- The display of the measurement channels is now reset to the factory setting.

## 6.3 Retrieving Measurement Data

All selected measurement channels and their measured values are recorded in the Sunny Central Control. You can retrieve the measurement data directly at the Sunny Central Control or via Sunny Data Control.

### 6.3.1 Retrieving Measurement Data at the Sunny Central Control

Proceed as follows to retrieve the measurement data directly at the Sunny Central Control.

1. Select "Long-Term Data > Meas. Chn. > SC...SCXXX".

```
[ Devices ]
*SC...SCC500HK
*Z4...SCBFS017
*Z3...SMU8b004
```

- The Sunny Central Control displays the measurement channels.

```
[SC:MEAS. DATA ]
*E-heute
*E-Total
*State
```

2. Select the required measurement channel with the [ ↓ ] arrow button and confirm with [ENTER].
  3. Select the required date with the [ ↓ ] arrow button and confirm with [ENTER].
- The Sunny Central Control displays the required measurement channel for the selected date.

### 6.3.2 Retrieving Measurement Data via Sunny Data Control

You can retrieve the measurement data via Sunny Data Control. The data is compiled in a channel record.

For more information on updating, refer to the Sunny Data Control manual.



## 6.4 Deleting Measurement Data

You can delete measurement data as described below:

1. Reset the measurement channels to the factory setting as described in Section 6.4 "Deleting Measurement Data" (page 33).
2. Select "Device Set-up > Parameters > Param.-Function".  
 The display blinks.
3. Select "Del. meas. data".  
 The display stops blinking.
4. Press [ENTER].  
 The measurement data is now deleted.

```
[ Parameters ]  
Param.-Function  
.....  
-----↓
```

```
[ Parameters ]  
Param.-Function  
Del Meas. Data  
-----↓
```

## 7 Parameters

The parameters of the Sunny Central are preset for operation. It is advisable to adapt some of the Sunny Central's parameters to the PV generator and to the requirements of grid security management.

The Sunny Central's parameters are subdivided into various menus:

- Red.effect.pow.  
Parameters for active power limitation
- Outp.react.pow.  
Parameters for the reactive power setpoint (these parameters are displayed, but are **not** supported.)
- Grid decoupling (disconnecting the Sunny Central from the grid)  
Parameters for grid decoupling
- Grid connection  
Parameters for grid connection
- Mpp Limit Val.  
Limit values for MPP mode
- MPP Tracking  
Settings for MPP mode
- Start requiremt  
Parameters for startup of the Sunny Central
- Shut-down requ  
Parameters for the controlled shutdown of the Sunny Central
- Grid Monitor.  
Parameters for grid conditions
- Other  
Various additional functions

## 7.1 Description of the Parameter Functions

The following parameters can be found in the menus. Parameters marked with \* may only be changed after consultation with SMA Solar Technology. Some parameters are preset by SMA Solar Technology and cannot be changed.

Parameters	Description of function
<b>Red.effect.pow.</b>	
P-WMod	This parameter is used to select the procedure for limiting active power.
P-W	This parameter is used to manually preset the active power limit in kW.
P-WNom	This parameter is used to manually preset the active power limit in percent.
Pac nominal	Nominal active power of the Sunny Central.
Pac max *	This parameter is used to restrict the active power. This is necessary, for example, if the feed-in power has to be limited at the grid node.
Smax	Maximum permissible apparent feed-in power
<b>Outp.react.pow. (Parameters in this menu are displayed but not supported)</b>	
<b>Grid decoupling / Grid voltage</b>	
VRtg	This parameter specifies the nominal line voltage of the public grid. All voltage data given as a percentage refers to this nominal voltage (100 % = VRtg).
VCtlhLim	Threshold value for triggering at overvoltage in Level 1.
VCtlhLimTm	Triggering time for the threshold value at overvoltage in Level 1.
VCtlhhLim	Threshold value for triggering at overvoltage in Level 2.
VCtlhhLimTm	Triggering time for the threshold value at overvoltage in Level 2.
VCtlLim	Threshold value for triggering at undervoltage in Level 1.
VCtlLimTm	Triggering time for the threshold value at undervoltage in Level 1.
VCtlIlLim	Threshold value for triggering at undervoltage in Level 2.
VCtlIlLimTm	Triggering time for the threshold value at undervoltage in Level 2.
VCtlMin	Minimum threshold value at undervoltage in Level 3.
VCtlMinTm	Triggering time for minimum threshold value at undervoltage in Level 3.
<b>Grid decoupling / Grid frequency</b>	
HzRtg	Nominal frequency of the energy supply grid
HzCtlhhLim	Threshold value for triggering at overfrequency in Level 2.
HzCtlhhLimTm	Triggering time for the threshold value at overfrequency in Level 2.
HzCtlhLim	Threshold value for triggering at overfrequency in Level 1.
HzCtlhLimTm	Triggering time for the threshold value at overfrequency in Level 1.
HzCtlLim	Threshold value for triggering at underfrequency in Level 1.
HzCtlLimTm	Triggering time for the threshold value at underfrequency in Level 1.
HzCtlIlLim	Threshold value for triggering at underfrequency in Level 2.
HzCtlIlLimTm	Triggering time for the threshold value at underfrequency in Level 2.
HzCtlMin	Minimum threshold value for triggering at underfrequency in Level 3.

Parameters	Description of function
HzCtlMinTm	Triggering time for the minimum threshold values at underfrequency in Level 3.
<b>Grid connection</b>	
GriGrdMonTm	This parameter defines the time span required to meet the switch-on conditions, before the Sunny Central can be reconnected to the energy supply grid.
VCtlOpMinNom	This parameter determines the minimum grid voltage, as a percentage of the nominal voltage VRtg, which must be present at the Sunny Central for it to reconnect to the energy supply grid.
VCtlOpMaxNom	This parameter defines the maximum grid voltage, as a percentage of the nominal voltage VRtg, which may be present at the Sunny Central for it to reconnect to the energy supply grid.
HzCtlOpMin	This parameter determines the minimum grid frequency which must be present at the Sunny Central for it to reconnect to the energy supply grid.
HzCtlOpMax	This parameter defines the maximum grid frequency which may be present at the Sunny Central for it to reconnect to the energy supply grid.
<b>Mpp Limit Val.</b>	
VmppMin *	Minimum MPP voltage required for the Sunny Central to feed.
dVreference	MPP tracking is possible within a range equal to $2 \times dVreference$ . As soon as the voltage breaches these voltage limits, the inverter changes to "MPP Search" mode. Default setting: 80 V Recommendation for operation with thin-film modules: 120 V
PsearchMpp *	If the currently measured PV power drops below the value PsearchMpp for the duration of TsearchMpp, the Sunny Central restarts the search for the MPP.
TsearchMpp *	
<b>MPP Tracking</b>	
dVtrack *	During MPP tracking, the inverter changes the voltage in "dUtrack" steps at "TcheckMpp" intervals before it selects the MPP.
TcheckMpp *	
Mpp Factor	The start value for MPP tracking is obtained by multiplying the "Mpp Factor" parameter by the measured open circuit voltage. Factory setting: 0.80 Recommendation for operation with thin-film modules: 0.70
TrackCnt	During operation, the Sunny Central searches the maximum power point. It checks the voltage up to seven times (default setting) in one direction, e.g. always toward the higher voltage. After the seventh time (at the latest), it also searches below the last voltage, in order to check whether the maximum power point has decreased. If, for example, the Sunny Central finds a lower power point upon the third increase, it searches below the most recently checked voltage.
<b>Start requirement</b>	
Operating mode *	MPP is set as a condition for starting up the inverter.

Parameters	Description of function
VconstSet	Setpoint for constant voltage operation.
VpvStart	Vpv must be > VpvStart for the duration of Tstart so that the Sunny Central can switch from "Wait" mode to "Startup" mode. The start voltage VpvStart must be adjusted to conform to the PV generator which is connected to the Sunny Central.
Tstart	
Twait	If, in three consecutive startup attempts, PpvStop is not exceeded, the next startup attempt will not occur before the Twait period has elapsed.
<b>Shut-down requirement</b>	
PpvStop *	If Ppv < PpvStop for the duration of Tstop, the Sunny Central goes into "Shutdown" mode.
Tstop	
<b>Grid Monitoring</b>	
PpvMinCheck *	PpvMinCheck appears only after entering the installer password. If PpvMinCheck is set to "off", the Sunny Central continues to operate after the shutdown conditions have been met. As a result, the Sunny Central will continue to operate at night and will have to draw its operating power from the grid.
ext.Power Swit.	Activation of grid disconnection
<b>Other</b>	
E-Total Offset	With this parameter, a constant offset can be applied to the internal energy counter. After replacement of the Sunny Central Control, it is advisable to adjust this parameter.
TMax. cabinet*	If cabinet temperature exceeds "TMax. cabinet", the warning "cabinet Temp." is generated.
TMin. cabinet*	If cabinet temperature drops below "TMin. cabinet", the warning "cabinet Temp." is generated.
Team-Funktion	Activating and deactivating team operation  For more information, refer to Sections . 14.6 "Disable Team Mode" (page 78) and 14.7 "Enable Team Mode" (page 79).

## 7.2 Default Parameter Settings

The following table gives a summary of the main operating parameters. It includes the adjustable range and default value of each parameter. The adjustable range and default value depend on the Sunny Central model.

The parameters marked with \* can only be displayed / changed after entering the installer password (see Section 5.6 "Enter Password" (page 27)).

Parameters	Area	Normal
VmppMin *	450 ... 880 V (SC 200 / SC 250 / SC 350 / SC 500) 540 ... 880 V (SC 560)	250 V (SC 100LV) 300 V (SC 125LV) 450 V (SC 500HE / SC 350HE / SC 350 / SC 250HE / SC 250 / SC 200HE / SC 200 / SC 150) 540 V (SC 560)
dVreference *	5 V ... 200 V	80 V
PsearchMpp *	0 ... 25000 W	device-specific setting
TsearchMpp *	60 ... 3600 s	600 s
dVtrack *	1 ... 10 V	5 V/TaMp
TcheckMpp *	10 ... 60 s	10 s
Mpp Factor *	0.20 ... 1.00	0.80
TrackCnt *	5 ... 20	7
VpvStart	200 ... 1000 V	400 V (SC 100LV / SC 125LV) 600 V (SC 500HE / SC 350HE / SC 350 / SC 250HE / SC 250 / SC 200HE / SC 200 / SC 150) 650 V (SC560HE)
Tstart	1 ... 600 s	90 s
Twait	0 ... 1800 s	600 s
PpvStop	0 ... 10000 W	device-specific setting
Tstop	1 ... 300 s	60 s
Pac max *	1 ... 1000 kW	device-specific setting
TMax. cabinet	30 ... 70 °C	50 °C
TMin. cabinet	-30 ... 10 °C	-20 °C

## 7.3 Changing Parameters



### Impaired functionality of Sunny Central due to changed parameters

Parameters which have not been changed properly can partly or completely impair the functionality of the Sunny Central.

- The parameters marked with \* may only be changed after consultation with SMA Solar Technology.
- After work has been carried out on the Sunny Central Control, it must be relocked in order to prevent any parameter alterations being carried out by third parties.



### Grid parameters

Certain parameters enable you to set values which are relevant for grid security. You must consult Sunny Central Service before making any changes to these parameters.

This chapter describes how you can adjust parameters at the Sunny Central Control. You can adjust the parameters by any of the following options:

- At the Sunny Central with Sunny Central Control.
- On site with a laptop and the Sunny Data Control software.
- Via remote access from a PC with Sunny Data Control, or via Sunny WebBox.

The Sunny Data Control or Sunny WebBox documentation describes how you can adjust parameters via Sunny Data Control or Sunny WebBox.

Please note that not all parameters can be adjusted via remote access. Certain parameters can only be adjusted when the Sunny Central is in the „Stop“ mode.

Change the parameters of the Sunny Central at the Sunny Central Control as described below:

1. Enter the password as described in Section 5.6 "Enter Password" (page 27).
2. Select "Device Set-up > Parameters".

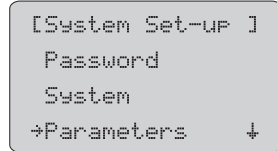

3. Press [ENTER] to select the menu in which a parameter is to be changed.
  4. Press [ENTER] to select the parameter to be changed.
  5. Make a note of the preset value of the parameter.
  6. Change parameter after consultation with SMA Solar Technology.
  7. Confirm the change with [ENTER].
- The required parameter has been changed.

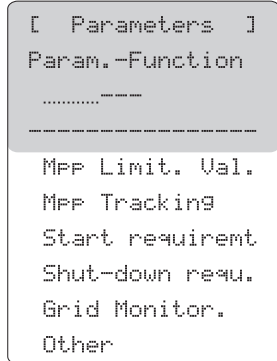

### 7.4 Resetting Parameters

To reset parameters, proceed as described in Section 7.3 "Changing Parameters" (page 39), and enter the original values of your Sunny Central.

### 7.5 Saving Parameters

Once parameters have been changed, save them as described below.

1. Enter the password as described in Section 5.6 "Enter Password" (page 27).
2. Select "Device Set-up > Parameters > save parameter".

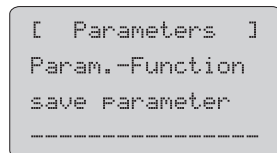

3. Press [ENTER] twice.
- The parameters are now saved.



## 8 Sending Data

Using the "NET Piggy-Back" option, the Sunny Central Control can be monitored remotely, and can send email reports concerning the operating status or present errors and events. Depending on your order preferences, the Sunny Central is delivered ex works either without any communication devices, or with a NET Piggy-Back in one of the three following versions:

- Analog
- ISDN
- Ethernet

The connection of Sunny Central Control to a telephone line, a router or a PC, is described in the NET Piggy-Back manual.

The Sunny Central Control is preset for the respective communication type. If you wish to receive email reports, you must adjust the setting for this. For further information on reports, please refer to Section 8.1 "Selecting Remote Info" (page 41).

### 8.1 Selecting Remote Info

1. Enter the password as described in Section 5.6 "Enter Password" (page 27).
2. Select „Device Set-up > NET/Email > Remote-Info“.

```
[ NET/Email ]
NET
→Remote-Info
```

- The menu shown to the right now appears.

```
[ REMOTE-INFO ]
E-mail
...Deactivated
-----
Events
Recipient
Sender
ISP Account
SMTP Account
Test-Report
```

## 8.2 Activating Email Reports

1. Select Remote Info as described in Section 8.1 "Selecting Remote Info" (page 41).
2. Press [ENTER].
  - The line below „E-mail“ starts to blink.
3. Select "activated" with the [ ↓ ] button.
  
4. Press [ENTER] twice.
  - The email reports are now activated.

```
[ REMOTE-INFO ]
E-mail
...activated
-----
```

## 8.3 Selecting Report Types to Send

1. Select Remote Info as described in Section 8.1 "Selecting Remote Info" (page 41).
2. Select "Events".
3. Select which reports should be sent at which time.

```
[ EVENTS ]
Plant-Info
...daily report
Warnings
...daily report
Errors
...hourly report
-----
Send at
.....20:00
```

### Report Types and Setting Options

Report	Description	Adjustable
Plant-Info	Report on the present values of your system, e.g. E-total, E-today.	<ul style="list-style-type: none"> <li>• No report</li> <li>• <b>Daily report (recommended)</b></li> </ul>
Warnings	Report of generated warnings.	<ul style="list-style-type: none"> <li>• No report</li> <li>• Hourly report</li> <li>• <b>Daily report (recommended)</b></li> </ul>

Report	Description	Adjustable
Errors	Report of errors which have occurred	<ul style="list-style-type: none"> <li>• No report</li> <li>• <b>Hourly report (recommended)</b></li> <li>• Daily report</li> </ul>
Event	<p>Report of generated events.</p> <p>In addition to the report, you can have the events displayed on Sunny Central Control under "Long-Term Data &gt; Plant Status".</p> <p>Refer to Section 15.1.5 "Events" (page 93) for a description of possible events.</p>	<ul style="list-style-type: none"> <li>• No report</li> <li>• Hourly report</li> <li>• <b>Daily report (recommended)</b></li> </ul>
Send at	Here you can set the time at which the daily report should be sent. SMA Solar Technology recommends setting the time to 22:15 (10.15 p.m.).	<ul style="list-style-type: none"> <li>• Time</li> </ul>

### 8.3.1 Daily Report "System Info"

The daily report "Plant Info" can contain the following information:

Von: <MEINE ANLAGE>  
 An: <MAX@MUSTERMANN.de>  
 Datum: 30.04.2009 11:02  
 Betreff: SUNNY-MAIL FIX Ertrag: 14.00kWh / Gesamt: 13.90kWh

ABSENDER : MEINE ANLAGE

EMPFAENGER: FIRMA XYZ-SOLAR, HERR MUSTERMANN

T A G E S B E R I C H T 30.04.2009

A N L A G E N - I N F O :

ID	GERAET	SERIENNUMMER	E-Total	E-Heute
SC	SCC-Test	0139100163	13.90kWh	14.00kWh

ENDE INFORMATION

Display	Description
ID	= SC
GERAET	= name of the Sunny Central concerned.
SERIENNUMMER	= serial number of the Sunny Central concerned.
E-Total	= total energy which the Sunny Central has fed into the grid during its operating life.
E-Heute	= energy which the Sunny Central has fed into the grid on the current day. This is the energy generated from the time the Sunny Central starts operating in the morning to the moment of the reading.

## 8.3.2 Hourly Report "Errors, Warnings and Events"

The hourly report "Errors, Warnings and Events" can contain the following information:

Von: <MEINE ANLAGE>  
 An: <MAX@MUSTERMANN.de>  
 Datum: 30.04.2009 11:02  
 Betreff: SUNNY-MAIL FIX Fehler: 4 / Warn.: 2 / Warn.SMU: 0

ABSENDER : MEINE ANLAGE

EMPFAENGER: FIRMA XYZ-SOLAR, HERR MUSTERMANN|

STUNDENBERICHT 30.04.2009 11:02

### F E H L E R :

ID	GERAET	SERIENNUMMER	DATUM	ZEIT	MELDUNG
SC	SCC-Test	0139100163	30.04.09	10:24	< Stoerung 400
SC	SCC-Test	0139100163	30.04.09	10:24	< Stoerung 110
SC	SCC-Test	0139100163	30.04.09	10:24	> Stoerung 400
SC	SCC-Test	0139100163	30.04.09	10:24	> Stoerung 110

### W A R N U N G (E N) :

ID	GERAET	SERIENNUMMER	DATUM	ZEIT	MELDUNG
SC	SCC-Test	0139100163	30.04.09	11:01	> Warnung 681
SC	SCC-Test	0139100163	30.04.09	11:00	< Warnung 681

### E V E N T (S) :

ID	GERAET	SERIENNUMMER	DATUM	ZEIT	MELDUNG
SC	SCC-Test	0139100163	30.04.09	11:01	> NSM
SC	SCC-Test	0139100163	30.04.09	11:00	< NSM
SC	SCC-Test	0139100163	30.04.09	10:59	> NSM
SC	SCC-Test	0139100163	30.04.09	10:59	< NSM
SC	SCC-Test	0139100163	30.04.09	10:56	> NSM
SC	SCC-Test	0139100163	30.04.09	10:56	< NSM

ENDE INFORMATION

Display	Description
ID	= SC
GERAET	= name of the Sunny Central concerned.
SERIENNUMMER	= serial number of the Sunny Central concerned.
DATUM	= date of the error, the warning or the event
ZEIT	= time at which the error, warning or event was detected by the Sunny Central > behind the time (before the message) means that the message appeared at the given time. < after the time (before the message) means that the message was cancelled at the given time.
MELDUNG	= number of the fault, warning or name of the event For more information on error or fault messages see Section 15 "Troubleshooting and Problem Solving" (page 80).

### 8.4 Entering or Changing an Email Address

1. Select Remote Info as described in Section 8.1 "Selecting Remote Info" (page 41).
2. Select "Recipient".



3. Enter a company name in the top line "FIRMA XYZ- SOLA" and confirm with [ENTER].
4. Enter your name in line 2 "HERRN MUSTERMA" and confirm with [ENTER].
5. Enter your email address in line 3 "EMAIL TO" and confirm with [ENTER].

In line four „EMAIL CC1" and line five "EMAIL CC2", you can enter two additional email addresses to which reports should be sent.

6. Confirm addresses with [ENTER].
- The email addresses are now entered.

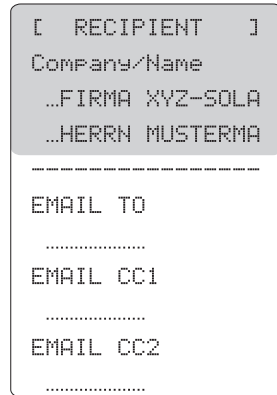

## 8.5 Sending a Test Report

1. Select Remote Info as described in Section 8.1 "Selecting Remote Info" (page 41).

2. Select "Test Report".

- In the display of Sunny Central Control "Start" appears.



→Start

3. Press [ENTER] to send a test report.

- The test report has now been sent.

**Or**

- The test report could not be sent. The message shown to the right is displayed. The meaning of the error code in the bottom line is described in the NET Piggy-Back manual.



FI-Status  
.....Fault  
[0016]

## 9 Analog Inputs

### Analog Sensors

In the Sunny Central it is possible to install two sensors (ExtSolIrr, ExtGloIrr) onto Sunny Central Control via the customer's terminal strip. The table below shows the various connection options available to the customer. These sensors can be configured by the customer.

If you have ordered the option "Installation in chemically active environment", the analog input "TmpExt C" will be allocated to a temperature sensor PT 100 at the factory. In this case, the ambient temperature will be measured outside the Sunny Central and will influence its operation behavior.

### External Signals

In addition to the analog sensors, three further signals can be connected: ExtAlarm, ExtSolP and ExtSolQ. These signals have a direct effect on the operation of the Sunny Central. The analog inputs ExtSolP and ExtSolQ serve to regulate active and reactive power.

This section describes how to activate the display of the sensors on the Sunny Central Control and how to configure them. The electrical connection of the sensors is described in the Sunny Central installation guide.

### Overview of Analog Inputs

Input	Meaning
ExtSolP	External setpoint specification for active power
ExtSolIrr	External radiation sensor
ExtGloIrr	Pyranometer (measurement of incident solar irradiation)
ExtAlarm	External alarm input, e.g. for monitoring the function of the medium-voltage transformer
ExtSolQ	External setpoint specification for reactive power
TmpExt C	External temperature sensor / PT 100 (will be supported only with option "Installation in chemically active environment")



## 9.1 Detecting External Sensors

1. Enter the password as described in Section 5.6 "Enter Password" (page 27).
2. Select "Device Set-up > Interfaces > Analog In".
3. Select the required analog input.

```
[ Analog In ]
→ExtSolIrr
  ExtGloIrr
  TmpExt C
```

- A detailed view of the required analog input is displayed. The figure to the right shows the detailed view of the analog input "ExtSolIrr".

```
[ ExtSolIrr ]
ctrl ExtSolIrr
.....off
Fkt ExtSolIrr
...deactivated
Gain
  1
Offset
  0
```

## 9.2 Calculating Gain and Offset

Calculating gain and offset using the example of "ExtSolIrr".

1. Detecting external sensors as described in Section 9.1 "Detecting External Sensors" (page 49).
2. Set "ctrl ExtSolIrr" to "on" to activate the analog input for the sensor.
3. Select a measurement range for the analog sensor , e.g. "+/-10V".

The displayed value is calculated by means of the following:

- the value measured by the sensor
- the value indicated for gain
- the value indicated for offset

```
[ ExtSolIrr ]
ctrl ExtSolIrr
.....on
Fkt ExtSolIrr
...+/- 10 V
Gain
1
Offset
0
```

4. Calculate the gain factor and the offset.

The gain factor is obtained by dividing the display range by the measured range.

**Gain factor = display range / measured range**

The offset is calculated by subtracting the product of gain factor x lower limit of measured range from the lower limit of the display range.

**Offset = lower limit of display range - (gain factor x lower limit of measured range)**

### Formulae

M is a value measured in a range between Ml and Mu.

D is the value to be displayed in a range between Dl and Du.

Gain:  $G = (Du - Dl) / (Mu - Ml)$

Offset:  $O = Dl - (G \times Ml)$

Display on the Sunny Central Control:  $D = (G \times M) + O$

### Explanation of the abbreviations used

M	measured value	Mu	upper limit of measured range
Ml	lower limit of measured range	O	Offset
G	Gain	D	Display value
Du	upper limit of display range	Dl	lower limit of display range

**Example calculation: pyranometer**

A pyranometer has an output voltage of 0 to 10 volt, which corresponds to an irradiation between 0 and 1350 W/m<sup>2</sup>.

$$\begin{aligned} M_l &= 0 \text{ V} & M_u &= 10 \text{ V} \\ D_l &= 0 \text{ W/m}^2 & D_u &= 1350 \text{ W/m}^2 \end{aligned}$$

Formula	Calculation
$G = (D_u - D_l) / (M_u - M_l)$	$G = (1350 - 0) / (10 - 0) = 135$
$O = D_l - (G \times M_l)$	$O = 0 - (135 \times 0) = 0 \text{ W/m}^2$

Example if  $M = 5 \text{ V}$

Formula	Calculation
$D = (G \times M) + O$	$135 \times 5 + 0 = 675$

**Example calculation: temperature sensor**

A thermometer with measurement transducer outputs 4 to 20 mA, which corresponds to a temperature range of -30 to 80 °C.

$$\begin{aligned} M_l &= 4 \text{ mA} & M_u &= 20 \text{ mA} \\ D_l &= -30 \text{ °C} & D_u &= 80 \text{ °C} \end{aligned}$$

Formula	Calculation
$G = (D_u - D_l) / (M_u - M_l)$	$G = (80 - (-30)) / (20 - 4) = 6.875$
$O = D_l - (G \times M_l)$	$O = (-30) - (6.875 \times 4) = -57.5 \text{ °C}$

Example if  $M = 4 \text{ mA}$ :

Formula	Calculation
$D = (G \times M) + O$	$4 \times 6.875 + (-57.5) = -30$

## 9.3 Configuring External Sensors

### 9.3.1 ExtSolIrr and ExtGloIrr

1. Open the detailed view of the sensor, as described in Section 9.1 "Detecting External Sensors" (page 49).
2. Activating or deactivating the external sensor.

#### ctrl ExtSolIrr, ctrl ExtGloIrr

Adjustable	Meaning
off	Sensor deactivated.
on	Sensor activated. After the sensor has been activated it is displayed under "Spot Values > Other". Also see Section 9.3.2 "Displaying Sensor Values" (page 53).

3. Setting the function of ExtSolIrr and ExtGloIrr.

#### Fct ExtSolIrr, Fct ExtGloIrr

Adjustable	Meaning
Deactivated	The analog input is deactivated
+/- 20 mA	Current measurement -20 mA to +20 mA
+/- 10 mV	Voltage measurement -10 mV to +10 mV
+/- 20 mV	Voltage measurement -20 mV to +20 mV
+/-50 mV	Voltage measurement -50 mV to +50 mV
+/- 100 mV	Voltage measurement -100 mV to +100 mV
+/- 500 mV	Voltage measurement -500 mV to +500 mV
+/- 1 V	Voltage measurement -1 V to +1 V
+/- 5 V	Voltage measurement -5 V to +5 V
+/- 10 V	Voltage measurement -10 V to +10 V

- ExtSolIrr and ExtGloIrr have now been configured.

#### Gain

Conversion factor. See Section 9.3.2 "Displaying Sensor Values" (page 53).

#### Offset

Value which is added. See Section 9.3.2 "Displaying Sensor Values" (page 53).

### 9.3.2 Displaying Sensor Values

1. Select "Spot Values > Others".

```
[Spot Values]
PV
Grid
+Other
```

2. Select the required sensor.
  - The present value is displayed under the sensor name.

## 9.4 Configuring External Messages

### 9.4.1 Setting ExtAlarm

The analog input ExtAlarm is preconfigured for the connection of an external alarm. Activate or deactivate monitoring as described below.

1. Open the detailed view of the sensor, as described in Section 9.1 "Detecting External Sensors" (page 49).
2. Set ExtAlarm.

```
[ ExtAlarm ]
ctrl ExtAlarm
...deactivated
```

**ctrl ExtAlarm**

Adjustable	Meaning
deactivated	Sensor is deactivated.
Active High	Alarm is triggered if 24 V are present at the alarm input terminal.
Active Low	Alarm is triggered if 0 V are present at the alarm input terminal.



**Email when alarm is triggered**

If you have activated the email report for "Warnings", you will receive an email immediately after the alarm has triggered.

## 9.4.2 Activating TmpExt C

The analog input "TmpExt C" is preconfigured for the connection of a temperature sensor. Activate or deactivate the analog input as described below:

1. Open the detailed view of the sensor, as described in Section 9.1 "Detecting External Sensors" (page 49).
2. Activating or deactivating the sensor.

```
[ TmpExt C ]
ctrl TmpExt C
...off
```

### ctrl TmpExt C

Adjustable	Meaning
off	Sensor deactivated.
on	Sensor activated. After the sensor has been activated it is displayed under "Spot Values > Other". Also see Section 9.3.2 "Displaying Sensor Values" (page 53).

# 10 Active Power Limitation

There are 3 different methods of limiting active power. You have the option of specifying a setpoint via the ExtSolP analog input or via a Sunny WebBox in connection with a Power Reducer Box. You can also set the limitation manually.

You also have the option of setting a frequency-dependent active power limitation. For more details, please see Section 10.2 "Active Power Limitation via Grid Frequency" (page 57).

## 10.1 Procedure for Setting Active Power Limitation

The "P-WMod" parameter is used to set the procedure for limiting active power. If you need help with this, please contact the Sunny Central Service.

Proceed as follows:

1. Select "Device Set-up > Parameters > Red.effect.pow. > P-WMod".  
 The line below "P-WMod" starts to blink.



2. Select the required procedure for limiting active power with the [ ↓ ] button.

The following procedures can be selected:

Procedure	Description
off	Active power is limited to the device nominal power "Pmax".
WcTLCom	The active power limit is received by the external control unit (e.g. Power Reducer Box) and transmitted to the Sunny Central via communication.
WcNst	The "P-W" parameter is set in kW via the communication (e.g. Sunny WebBox).
WcNstNom	The "P-WNom" parameter is set as a percentage via the communication (e.g. Sunny WebBox).
WcNstNomAnln	The active power limitation is set via a signal at the analog input ExtSolP. The analog value is converted to a setpoint for power limitation.

3. Press [ENTER] twice to confirm the procedure.  
 The required procedure for active power limitation has now been set.

**Procedure "WCnstNomAnIn"**

If you have selected the procedure "WCnstNomAnIn", you must connect a signal to the analog input "ExtSolP" of the Sunny Central. The strength of the connected signal current determines the nominal active power in percent.

<b>Current</b>	<b>Nominal active power</b>
4 mA	0 %
8.5 mA	30 %
11.5 mA	50 %
13 mA	60 %
19 mA	100 %



## 10.2 Active Power Limitation via Grid Frequency

The downward regulation of active power via the grid frequency is based on the available power at the start time of the downward regulation. If the grid frequency exceeds a certain threshold defined by you (P-HzStr), for example 50.2 Hz, the Sunny Central saves the feed-in power value at that moment in time. Depending on grid frequency, the saved value defines the power limit. The gradient of the limit can be set via the P-WGra parameter (standard = 40 %). Should the grid frequency drop, the last power limit reached remains in effect. Increasing the feed-in power is only permissible when grid frequency drops below, for example, 50.05 Hz (P-HzStop).

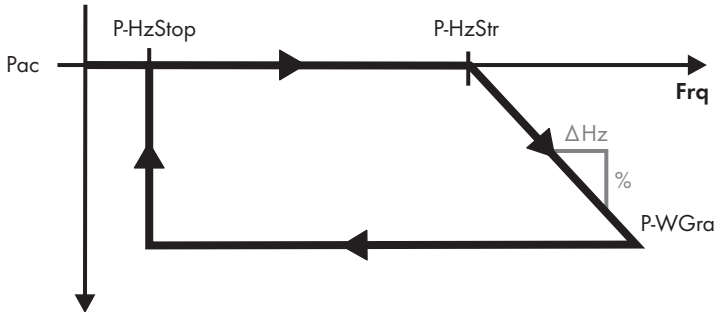

### Example:

A Sunny Central with 500 kW capacity is currently feeding 350 kW ( $P_{\text{mom}}$ ) into the public grid. The frequency rises to 51.2 Hz. From the difference between the current grid frequency and P-HzStr (51.2 Hz - 50.2 Hz) multiplied by the gradient P-WGra (40 %) we arrive at a reduction of active power by 40 % of the last available power  $P_{\text{mom}}$  (350 kW). This results in a power limitation of 140 kW and a maximum active power of 210 kW.

**Formula:**  $P_{\text{Grenz}} = P_{\text{mom}} - ((f_{\text{Netz}} - P\text{-HzStr}) / \text{Hz}) * P\text{-WGra} * P_{\text{mom}}$

$P_{\text{Grenz}}$  = limit power

$P_{\text{mom}}$  = current power

### Calculation for this example:

$$210 \text{ kW} = 350 \text{ kW} - ((51.2 - 50.2) * 40 \% * 350 \text{ kW})$$



### Deactivating active power limitation via grid frequency

If you wish to deactivate the active power limitation via grid frequency, please contact Sunny Central Service.

# 11 Grid Monitoring

The Sunny Central monitors the energy supply grid for breaches of adjustable upper or lower limit values. If the upper or lower limit values are breached for a relevant adjustable time, the Sunny Central disconnects itself from the grid for security reasons.

The following limit values are monitored:

- Voltage decrease protection  $U<$  and  $U<<$
- Voltage increase protection  $U>$  and  $U>>$
- Frequency decrease protection  $f<$ ,  $f<<$  and  $f<<<$
- Frequency increase protection  $f>$  and  $f>>$

For each limit value, you can set a trigger delay time, for the duration of which the grid fault must be present before the Sunny Central disconnects from the grid.

Thus, for example, at an overfrequency of 50.5 Hz triggering can be set to take place after 1 second, and at an overfrequency of 51.5 Hz after only 0.1 seconds.

You can preset the limit values and the triggering time manually. For voltage monitoring, it is possible to set two limits each for overvoltage and undervoltage. For frequency monitoring, you can set 2 upper limits and 3 lower limits.

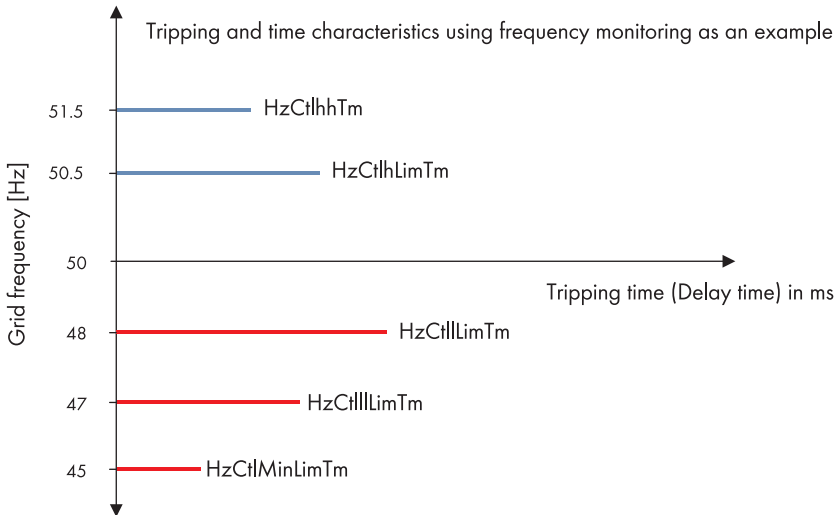

## 11.1 Grid Connection after Fault Clearance

After clearance of a grid fault, reconnection can only occur once the grid voltage has returned to within the set connection limits: (e.g.  $VctOpMinNom$ ) for the duration of the grid monitoring time ( $GriGrdMonTm$ ).

## 11.2 Behavior of Grid Limits over Time when Breaches Occur

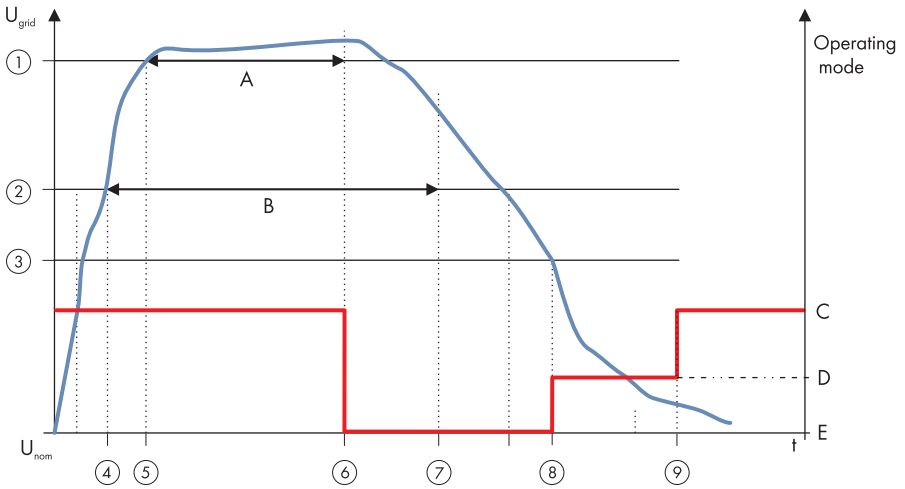

Object	Description
A	Delay time for grid limit Level 2
B	Delay time for grid limit Level 1
C	Start up / MPP load operation
D	Grid Monitoring
E	Failure
1	Grid limit Level 2
2	Grid limit Level 1
3	Connection limit
4	Grid limit Level 1 is breached, timer starts
5	Grid limit Level 2 is breached, timer starts
6	Grid limit level 2 for delay time level 2 is breached → grid disconnection
7	Grid limit Level 1 for delay time Level 1 is breached → grid disconnection (the grid has already disconnected at Level 2)
8	Connection conditions fulfilled → monitoring time starts
9	Grid within valid range during monitoring time → grid connection

### 11.3 Setting the Medium-Voltage Level (applicable only to HE devices)

You can set the medium-voltage level for display and grid monitoring. You can set the grid voltage to the appropriate value via the parameter "VRtg". The default value of the parameter "VRtg" is 20 kV. It is important to adjust the transmission ratio of the external medium-voltage transformer at the same time. To do this, you only have to adjust the high-voltage side via the parameter "TrfVolExlHi". The value must equal the value of the parameter "VRtg". The low-voltage side is preset according to the specific device.

**Important: you must always set the phase conductor voltages.**

### 11.4 Disconnection Protection Ramp (DCRmp)

After a grid failure the Sunny Central slowly starts up again, with a disconnection protection ramp of max. 10 % of the nominal power per minute. You have the option of switching this disconnection protection ramp on or off. For Germany, the disconnection protection ramp is standardly switched on. If you switch the disconnection protection ramp off, the Sunny Central runs up to maximum output in the shortest time possible.



#### **Activating/deactivating the disconnection protection ramp**

If you wish to activate or deactivate the disconnection protection ramp, please consult the Sunny Central Service.

## 12 External Grid Monitoring Relay (optional)

All Sunny Central inverters with an integrated transformer use an external grid monitoring relay to monitor the connected grid. This relay detects and signals breaches of the grid limits and transmits a fault signal to the Sunny Central. Devices without an integrated transformer can optionally be fitted with this relay.

If a grid monitoring relay is fitted, the grid limits in the Sunny Central software are expanded and thus deactivated. In this case, grid monitoring takes place via the external grid monitoring relay.

The parameters for the grid limits are then set directly at the grid monitoring relay.

The following illustration shows the position of the grid monitoring relay, based on the example of a Sunny Central 250HE.

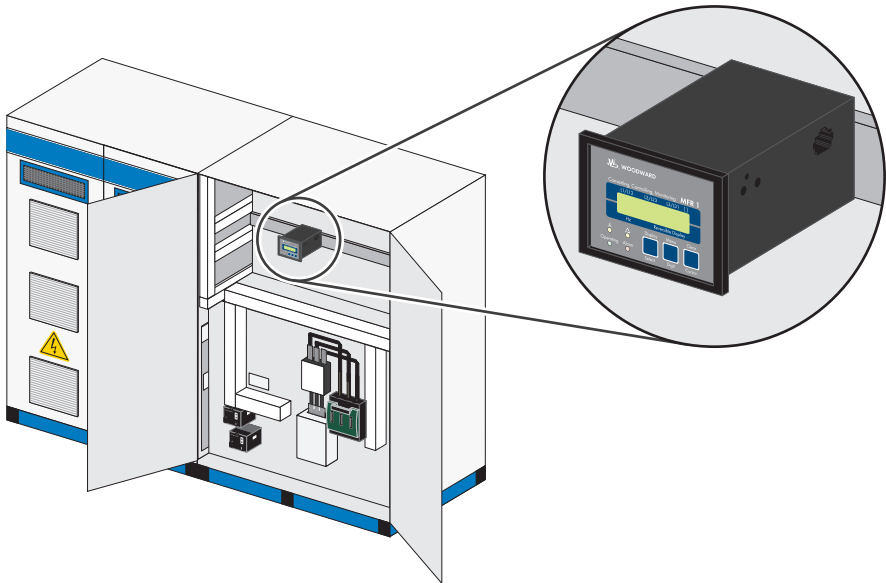

## 12.1 Overview of the Display and Control Elements

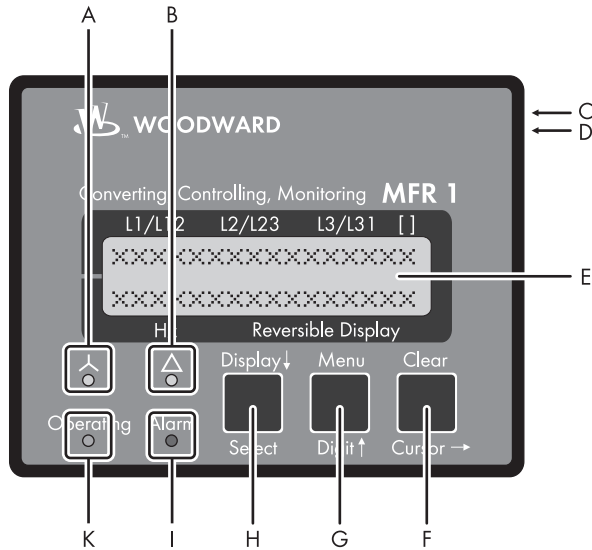

Object	Name	Function
A	Wye (Y)	Display of wye (star) voltages (phase conductor - neutral conductor)
B	Delta ( $\Delta$ )	Display of delta voltages
C	DPC slot	Configuration port
D	Potentiometer	Set LCD contrast
E	LCD	2-line LC display
F	Clear Cursor →	Clear alarm signal Move one position to the right
G	Menu Digit ↑	Selecting a Menu Increase selected number
H	Display ↓ Select	Scroll through display line Confirm selection
I	Alarm	An alarm has occurred
K	Operating	Auto mode

## 12.2 Display Messages

Performance values can be monitored from the two-line display, provided that the grid monitoring relay is in automatic mode. In the configuration mode, the individual parameters are displayed.

### Display in auto mode, top line: measured values

By means of the "Display ↓" button you can scroll through the first line of the display.

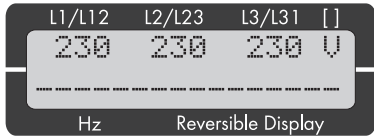
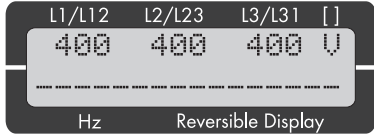
Display	Description
	<p>The "star" LED is on and the "triangle" LED is off.</p> <p>The wye (star) voltages (<math>U_{L1-N}</math>, <math>U_{L2-N}</math> and <math>U_{L3-N}</math>) of the four-wire system are displayed.</p>
	<p>The "star" LED is off and the "triangle" LED is on.</p> <p>The phase conductor voltages (<math>U_{L1-L2}</math>, <math>U_{L2-L3}</math> and <math>U_{L3-L1}</math>) of the three-wire system are displayed.</p>

### Display in auto mode, bottom line: measured values

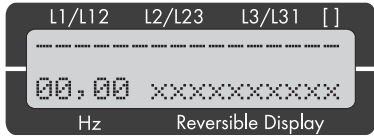

By means of the „Menu“ button you can scroll through the second line of the display.

Display	Description
	<p>In the bottom line the frequency [Hz] is displayed.</p>

## 12.3 Configuration

You may only carry out configuration when the Sunny Central is not in operation.

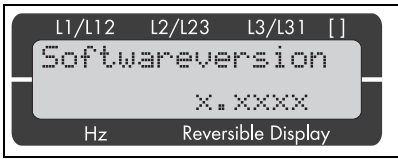
### 12.3.1 Changing from Automatic Mode to Configuration Mode

	<p><b>Configuration mode "Select"</b></p> <p>By pressing the "Select" button, you will activate the input mode and be able to view the following screens and to make adjustments within the specified limits. Each time you press "Select", you will scroll down one of the screens below. If you have configured a parameter to "OFF", the relevant screen will not be displayed and you cannot process it. By pressing "Select" you can switch the display to the next parameter.</p>
	<p><b>Software version</b></p>
	<p><b>Select language German / English</b></p>



## 12.3.2 Access to Configuration

### Password protection

You will need a password to carry out any parameter settings / adjustments. Once you have entered this password, you can view and adjust all parameters.

The factory setting for the password is <4753>.

You are free to change the password as desired. Keep the password safe to prevent any unauthorized parameter adjustments.

 <b>DANGER!</b> Danger to life through changing the internal safety specifications of the Sunny Central.	
<ul style="list-style-type: none"> <li>Only qualified electricians may carry out parameter adjustments.</li> <li>Only adjust parameters after consultation with the SMA Serviceline.</li> </ul>	

### Enter Password

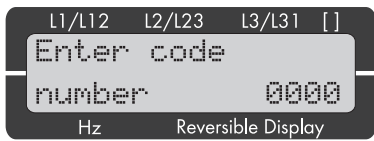
	<b>Enter code number 0000 - 9999</b> Input screen for the password
---	---

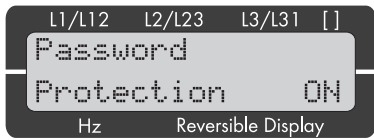
	<b>Password Protection ON / OFF</b> ON = Password protection is activated. OFF = Password protection is deactivated.
---	--

### Change password

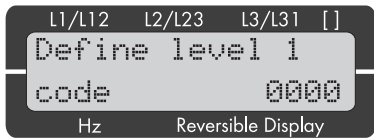
	<b>Define password for code level 1</b> The password is preset to: CS1 = 0001
---	--

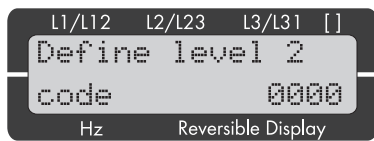
	<b>Define password for code level 2</b> The password is preset to: CS2 = 4753
---	--

### 12.3.3 Parameters

#### Voltage measurement

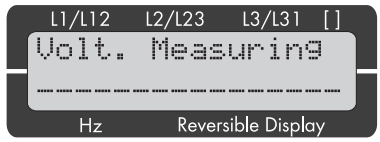
	<p><b>Voltage measurement</b>  <b>Four-wire system / three-wire system</b>  <b>Do not change</b></p>
---	--

#### Voltage transformer configuration

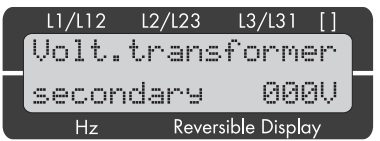
	<p><b>Voltage transformer secondary</b>          Device-specific presetting, <b>do not change.</b></p>
---	--

Adjust the setting for the primary voltage transformer to the medium-voltage value to match your system. This setting has no effect on monitoring, but only on the display of voltage readings.

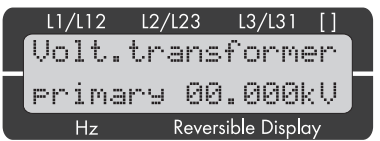
	<p><b>Voltage transformer primary</b>          For Sunny Central devices without an integrated transformer, enter the voltage of the medium-voltage side (e.g. 20 kV).          For Sunny Central devices with an integrated transformer, this parameter is preset according to the specific device <b>and the setting must not be changed.</b></p>
---	---

### 12.3.4 Monitoring

	<p><b>Monitoring for...</b>  <b>Three-wire / four-wire system; default for Sunny Central with integrated transformer: four-wire system; default for Sunny Central without integrated transformer: three-wire system</b>  <b>Do not change</b></p>
---	---

This parameter is masked out as soon as you have set the "voltage measurement" parameter to three-wire system.

When setting the voltage thresholds please note the following:

- Sunny Central with integrated transformer: set the threshold values as absolute values in volts, corresponding to those present at the grid connection.

- Sunny Central with external medium-voltage transformer: set the values in volts. Set the relative value as a percentage of nominal voltage (105 V are equivalent to 105 % of nominal voltage).
- Frequency thresholds are always set as absolute values in Hertz.

**Example:**

If a system with 20 kV / 100 V has an overvoltage threshold of 115 V (115 %) and a hysteresis of 5 V (5%), the monitored voltage must fall below 110 V (110 %) in order that the alarm be reset.

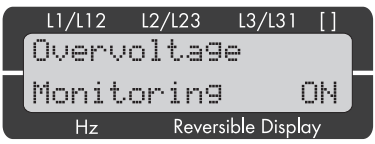
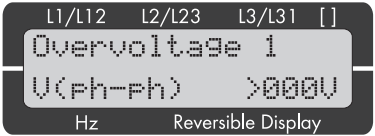
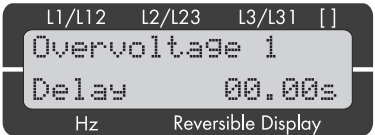
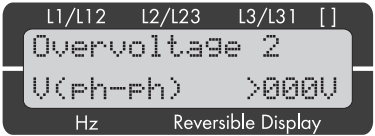
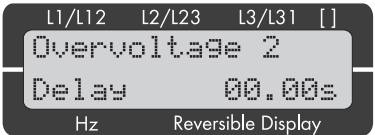
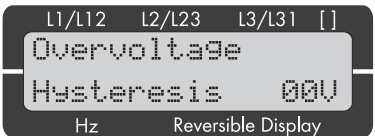
	<p><b>Overvoltage Monitoring ON / OFF</b></p> <p>ON = Overvoltage monitoring is activated. The following parameters of this function will be displayed.                  OFF = Overvoltage monitoring is deactivated. The following parameters of this function will not be displayed.</p>
<p>Parameters for "3-wire system":</p> 	<p>Threshold value for triggering at overvoltage in Level 1</p>
	<p>Delay time for threshold value at overvoltage in Level 1</p>
<p>Parameters for "3-wire system":</p> 	<p>Threshold value for triggering at overvoltage in Level 2</p>
	<p>Delay time for threshold value at overvoltage in Level 2</p>
	<p>Hysteresis for the overvoltage monitoring; this must be exceeded before any reconnection is possible.</p>

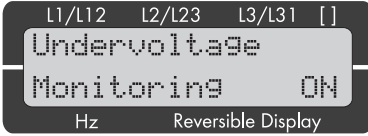
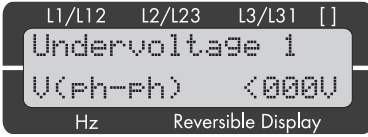
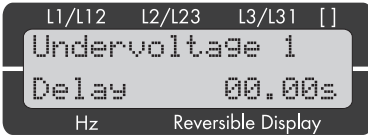
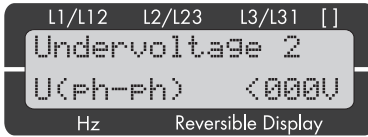
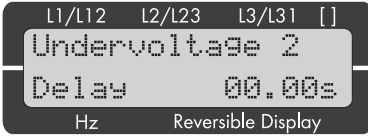
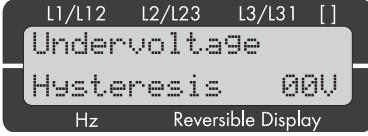
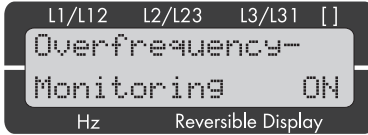
	<p><b>Undervoltage monitoring ON / OFF</b></p> <p>ON = Undervoltage monitoring is activated. The following parameters of this function will be displayed.          OFF = Undervoltage monitoring is deactivated. The following parameters of this function will not be displayed.</p>
<p>Parameters for <b>"3-wire system"</b>:</p> 	<p>Threshold value for triggering at undervoltage in Level 1</p>
	<p>Delay time for threshold value at undervoltage in Level 1</p>
<p>Parameters for <b>"3-wire system"</b>:</p> 	<p>Threshold value for triggering at undervoltage in Level 2</p>
	<p>Delay time for threshold value at undervoltage in Level 2</p>
	<p>Hysteresis for the undervoltage monitoring; this must be exceeded before any reconnection is possible.</p>
<p>Voltage assymetry monitoring</p>	<p><b>not supported</b></p>
	<p><b>Overfrequency Monitoring ON / OFF</b></p> <p>ON = Overfrequency monitoring is activated. The following parameters of this function will be displayed.          OFF = Overfrequency monitoring is deactivated. The following parameters of this function will not be displayed.</p>

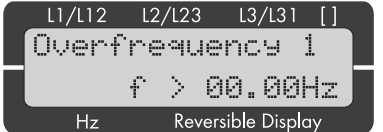
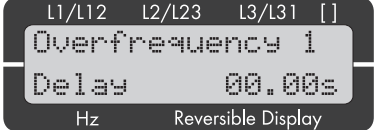
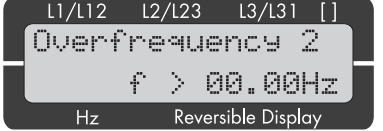
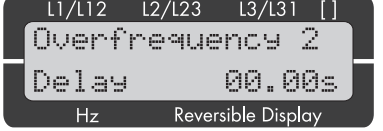
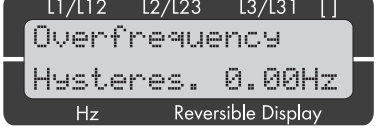
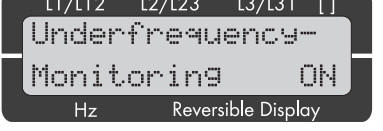
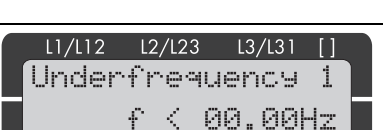
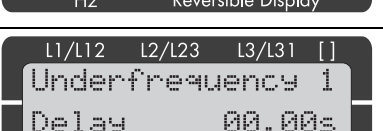
 <p>L1/L12 L2/L23 L3/L31 [ ] Overfrequency 1 f &gt; 00.00Hz Hz Reversible Display</p>	<p>Threshold value for triggering at overfrequency in Level 1</p>
 <p>L1/L12 L2/L23 L3/L31 [ ] Overfrequency 1 Delay 00.00s Hz Reversible Display</p>	<p>Delay time for threshold value at overfrequency in Level 1</p>
 <p>L1/L12 L2/L23 L3/L31 [ ] Overfrequency 2 f &gt; 00.00Hz Hz Reversible Display</p>	<p>Threshold value for triggering at overfrequency in Level 2</p>
 <p>L1/L12 L2/L23 L3/L31 [ ] Overfrequency 2 Delay 00.00s Hz Reversible Display</p>	<p>Delay time for threshold value at overfrequency in Level 2</p>
 <p>L1/L12 L2/L23 L3/L31 [ ] Overfrequency Hysteres. 0.00Hz Hz Reversible Display</p>	<p>Hysteresis for the overfrequency monitoring; this must be exceeded before any reconnection is possible.</p>
 <p>L1/L12 L2/L23 L3/L31 [ ] Underfrequency- Monitoring ON Hz Reversible Display</p>	<p><b>Underfrequency Monitoring ON / OFF</b> ON = Underfrequency monitoring is activated. The following parameters of this function will be displayed. OFF = Underfrequency monitoring is deactivated. The following parameters of this function will not be displayed.</p>
 <p>L1/L12 L2/L23 L3/L31 [ ] Underfrequency 1 f &lt; 00.00Hz Hz Reversible Display</p>	<p>Threshold value for triggering at underfrequency in Level 1</p>
 <p>L1/L12 L2/L23 L3/L31 [ ] Underfrequency 1 Delay 00.00s Hz Reversible Display</p>	<p>Delay time for threshold value at underfrequency in Level 1</p>

<p>L1/L12 L2/L23 L3/L31 [] Underfrequency 2 f &lt; 00.00Hz Hz Reversible Display</p>	<p>Threshold value for triggering at underfrequency in Level 2</p>
<p>L1/L12 L2/L23 L3/L31 [] Underfrequency 2 Delay 00.00s Hz Reversible Display</p>	<p>Delay time for threshold value at underfrequency in Level 2</p>
<p>L1/L12 L2/L23 L3/L31 [] Underfrequency Hysteres. 0.00Hz Hz Reversible Display</p>	<p>Hysteresis for the underfrequency monitoring; this must be exceeded before any reconnection is possible.</p>
<p>L1/L12 L2/L23 L3/L31 [] External Clearing ON Hz Reversible Display</p>	<p><b>not supported</b></p>
<p>L1/L12 L2/L23 L3/L31 [] Auto-clearing Relays ON Hz Reversible Display</p>	<p>Factory setting is "On" If you set the parameter to "Off", there will be no automatic reset and after a grid failure the Sunny Central will remain permanently in the alarm state.</p>
<p>L1/L12 L2/L23 L3/L31 [] Release delay xxxxxxx 00.00s Hz Reversible Display</p>	<p><b>Delay time for automatic reset of relay outputs after error message Configurable for the following types of monitoring.</b></p>

Monitoring for	Display message instead of XXXXXXXX	Comment
Overvoltage	Overvolt.	Overvoltage, Levels 1 and 2
Undervoltage	Und.volt.	Undervoltage, Levels 1 and 2
Overfrequency	Overfreq.	Overfrequency, Levels 1 and 2
Underfrequency	Underfrq.	Underfrequency, Levels 1 and 2

<p>L1/L12 L2/L23 L3/L31 [] Auto-clearing Display ON Hz Reversible Display</p>	<p>With this parameter you can set the display error message to reset automatically after the error has been indicated.</p>
<p>L1/L12 L2/L23 L3/L31 [] Quittierung Meldung nach 00s Hz Reversible Display</p>	<p><b>Delay time for reset of display message after error signal</b></p>
<p>L1/L12 L2/L23 L3/L31 [] Change relay- allocation? YES Hz Reversible Display</p>	<p><b>Change relay allocation YES / NO</b> Device-specific presetting, <b>do not change</b></p>
<p>L1/L12 L2/L23 L3/L31 [] XXXXXXXXXXXXXXXXXXXXX to relay 0000 Hz Reversible Display</p>	<p><b>Assign protection functions to relays 0 to 3</b> <b>Device-specific presetting, do not change</b></p>
<p>L1/L12 L2/L23 L3/L31 [] Funct. relay 123 (R=releases) RRR Hz Reversible Display</p>	<p><b>Function of relays 1, 2 and 3</b> <b>Preset, do not change</b></p>

## 12.4 Alarm Messages / Dealing with Errors

Depending on the cause of the error, various error messages will appear on the display.

By means of the „Menu“ button you can scroll through the alarm messages.

Alarm text	Description
Overvolt. 1	The threshold value for Level 1 of overvoltage monitoring has been exceeded.
Overvolt. 2	The threshold value for Level 2 of overvoltage monitoring has been exceeded.
Und.volt. 1	The threshold value for Level 1 of undervoltage monitoring has been exceeded.
Und.volt. 2	The threshold value for Level 2 of undervoltage monitoring has been exceeded.
Overfreq. 1	The threshold value for Level 1 of overfrequency monitoring has been exceeded.
Overfreq. 2	The threshold value for Level 2 of overfrequency monitoring has been exceeded.
Und.freq. 1	The threshold value for Level 1 of underfrequency monitoring has been exceeded.
Und.freq. 2	The threshold value for Level 2 of underfrequency monitoring has been exceeded.

### 12.4.1 Clear Alarm Signal

The grid monitoring relay signals an error / alarm via the "Alarm" LED.

You can clear the alarm signal by pressing the "Clear" button. We distinguish between the following error states:

- Error still present:  
As long as the error is still present it cannot be cleared. The blinking "Alarm" LED on the control panel indicates that the alarm state is still active.
- Error no longer present:  
Once the current error has been remedied, the "Alarm" LED changes from blinking to continuously lit. The relay is configured such that the error message is automatically reset after the error has been signalled and the reset time has elapsed.

### 12.4.2 Interface

A configuration interface is available for configuring the relay via a PC: To do this you need a special interface cable (DPC) and software. You can find further information in the relay manual. This is supplied with the Sunny Central on a CD-ROM or you can find it on the internet under [www.woodward.com](http://www.woodward.com).



## 13 Islanding Detection (Anti-Islanding)

In cases of grid failure the grid voltage drops. The Sunny Central detects this via grid monitoring and switches off. In unfavorable circumstances there is the possibility that the Sunny Central is feeding the grid with a certain output, for example 100 kW, while at the same time there is 100 kW load running on the same grid branch. In this case, an island grid will be formed and the Sunny Central will supply the 100 kW load. Here, the Sunny Central will measure its own voltage and, finding it equal to the grid voltage, will not immediately disconnect from the grid. However, if the anti-islanding (island detection) function is activated, the Sunny Central will detect the formation of an island grid and disconnect from the grid within a few seconds.



### **DANGER!**

**Danger to life due to high voltages in the case of presumed disconnection from the grid. Death or serious burns.**

In a case such as that described above, voltage will still be present despite presumed disconnection from the grid.

- SMA Solar Technology recommends activating the "Anti-islanding" option.
- Contact the Sunny Central Service if you wish to have the "Anti-islanding" option activated.
- Always makes sure there is no voltage present before working on the Sunny Central or the grid.

## 14 Sunny Team (optional)

You have the option of operating two Sunny Centrals with identical nominal power as a Sunny Team. Sunny Team is a circuit with a DC contactor which connects the two Sunny Centrals electrically. In case of low solar radiation the DC contactor closes and the two Sunny Centrals (manager and team member) are connected in parallel on the DC side. One Sunny Central converts the power of the entire system and feeds it into the public grid. The team manager and the team member take turns to feed into the grid. The team manager feeds into the grid on even-numbered days and the team member on odd-numbered days. While one Sunny Central is feeding into the grid, the other changes to "Wait" mode.

### Requirements for team operation:

- 2 Sunny Centrals with the same nominal power
- 2 Sunny Centrals are equipped with Sunny Team
- Same number of PV modules per string
- PV modules of the same type
- PV modules with identical vertical and horizontal arrangement

The connection of the team cabling and the installation of team systems is described in the Sunny Central installation guide.

### Manager device

The manager device is responsible for the operational control of the team and insulation monitoring of the entire system. In cases of low solar radiation, the manager device specifies which team member should feed the entire system power into the grid, and which team member should switch to "Wait" mode.

### Team device (team member)

In team operation, the insulation monitoring system of the team member is in "Standby" mode. Two insulation monitoring systems cannot operate simultaneously, as the two devices would interfere with each other.

## 14.1 Identification of Manager Device and Team Device

The type label includes a version key which specifies whether the Sunny Central is the manager or the team device. You can identify the Sunny Central's team function by comparing the version key on the type label with the explanation of the version key in the wiring diagram.

## 14.2 Display of Team Mode on the Sunny Central

In team mode, the indicator light for team operation is lit on both Sunny Centrals. The DC contactor is closed, one Sunny Central feeds the entire system power into the public grid.

### 14.3 Operating States of Sunny Team

During normal daily operation, the Sunny Team goes through four phases. These 4 phases are described below.

Phase	Explanation
In the morning	$V_{pv} > V_{pvStart} - 50 \text{ V}$ : The DC contactor closes. The system changes to team mode. The Sunny Centrals are factory preset for alternating grid feed. The team manager feeds into the grid on even-numbered days and the team member on odd-numbered days. The Sunny Central designated for grid feed goes into operation as soon as the start requirements are fulfilled, and feeds the entire system power into the public grid.
80 % of AC nominal power exceeded	$AC \text{ nominal power} > P_{Next \text{ Team}}$ (default setting 80 %): The DC contactor opens. The two Sunny Centrals now work separately. Both Sunny Centrals are in operation, converting the power of their PV generator and feeding it into the public grid.
Power drops below 20 % of "Pac smoothed".	$P_{ac \text{ smoothed}} < P_{Prev \text{ Team}}$ (default setting 20 %): the DC contactor closes. The system switches to Team mode. The team manager determines which Sunny Central is to convert the energy and feed into the grid. The grid-feeding Sunny Central feeds the entire system power into the public grid.
In the evening	Open-circuit voltage of the grid-feeding Sunny Central for 30 minutes $< V_{pvmin} - 100 \text{ V}$ : the DC contactor opens. The Sunny Centrals are disconnected from each other. This state is maintained until the following morning.

## 14.4 Team Status

You can call up the status of the Sunny Team in Sunny Central Control under "Spot values > Other > Team status".

### Description of team status

Status German	Status English	Description
Deaktiviert	Deactivated	Team mode is now deactivated.
Init	Init	Initializing team mode.
Stop	Stop	Team mode is stopped.
Warten	Wait	The Sunny Central is waiting for sufficient solar radiation to go into operation mode.
Warte gekoppelt	Wait Linked	The Sunny Centrals are linked. The Sunny Central is not feeding into the grid.
Einsp.gekoppelt	Feed Linked	The Sunny Centrals are linked. The Sunny Central is feeding the entire system power into the public grid.
Unabh. Einsp.	Feed SingleMode	The Sunny Centrals are not linked. They are feeding into the grid independently of each other.

## 14.5 Team Mode Interrupted

An interruption of team operation can have various causes. These will be described in this section.

### Key switch set to "STOP"

If one of the two Sunny Centrals is switched off, team operation is not possible. The Sunny Centrals connect individually to the grid.

### Emergency shut-off switch actuated

Depending on the wiring option, the emergency shut-off switches of the Sunny Centrals in team operation are either interconnected or not interconnected. SMA Solar Technology recommends connecting the emergency shut-off switches of both Sunny Centrals in the team.

- Emergency shut-off switches electrically interconnected:
  - Both Sunny Centrals change to "Emergency shut-off" mode. Neither grid feed nor team operation is possible.
- Emergency shut-off switches not interconnected, no team operation.
  - The Sunny Central with the emergency shut-off switch actuated switches to "Emergency shut-off" mode.
  - If the second Sunny Central is the team manager, it will remain in its current operating mode. Team operation is not possible.
- Emergency shut-off switches not interconnected, team operation.
  - The Sunny Central with the emergency shut-off switch actuated switches to "Emergency shut-off" mode.
  - The second Sunny Central is the team manager and was in "Wait" mode. It feeds the energy from its PV generator into the public grid. Team operation is not possible.
  - The second Sunny Central is the team manager and was not in "Wait" mode. Neither grid feed nor team operation is possible.

## Failure of a Sunny Central

If a fault occurs in a Sunny Central, team operation is immediately interrupted and the DC contactor opens. The Sunny Centrals operate separately until the error is cleared. If a failure is present for more than 60 minutes, team operation is possible under the following conditions:

- Communication system is running.
- DC contactor works.
- Sunny Central is switched on with the key switch.

Team operation is not possible if one of the following faults is present:

- Failure 201: ground fault or overtemperature.
- Failure 206: Emergency shut-off Emergency shut-off actuated.

If these requirements are fulfilled, the Sunny Central not displaying the failure will feed the entire system power into the public grid.

## 14.6 Disable Team Mode

If you do not want to run the two Sunny Centrals in team operation, you can disable the team mode. The team mode must be deactivated on both the Sunny Centrals in the team.

Proceed as follows:

1. Enter the password as described in Section 5.6 "Enter Password" (page 27).
2. Select "Device Set-up > Parameters > Others > Team function".
  - The line below "Team function" starts to blink.
3. Note the Sunny Central's current function in the team. Retain this note in case the team mode needs to be reactivated.

```
[ Other ]
E-Total Offset
.....0.00kWh
TMax. cabinet
.....50°C
TMin. cabinet
.....-20.00°C
Team function
->...Team unit  ↑
```

4. Select "deactivated" with the [ ↓ ] button.
5. Press [ENTER].
  - Team mode is now deactivated.
6. Disable team mode in the second Sunny Central.
  - Team mode in both Sunny Centrals is now deactivated.

## 14.7 Enable Team Mode

If you wish to revert to team operation of the two Sunny Centrals, you can re-enable team mode. The team mode must be activated at both the Sunny Centrals in the team.

Proceed as follows:

1. Enter the password as described in Section 5.6 "Enter Password" (page 27).
2. Select "Device Set-up > Parameters > Others > Team function".
  - The line below "Team function" starts to blink.

```
[  Other  ]
E-Total Offset
.....0.00kWh
TMax. cabinet
.....50°C
TMin. cabinet
.....-20.00°C
Team function
↔...Deactivated ↔
```

3. With the [ ↓ ] button assign the previously noted team function of the Sunny Central. This must be identical with the function prior to deactivation.



### Function of the Sunny Central in the Team

If you did not note the Sunny Central's function within the team, you can identify this function as described in Section 14.1 "Identification of Manager Device and Team Device" (page 74).

4. Press [ENTER].
  - Team mode is now enabled.
5. Enable team mode in the second Sunny Central.
  - Team mode in both Sunny Centrals is now enabled.

# 15 Troubleshooting and Problem Solving

**DANGER!**  
**Danger to life due to high voltages in the Sunny Central! Death or serious burns.**

Even in cases of failure, the Sunny Central can retain high voltages.

- Only qualified technical personnel may perform any of the work described in this section. "Qualified" means that the personnel must possess training relevant to the activity performed.
- Work on the Sunny Central must only be carried out as described in this manual.
- Comply with all the listed safety instructions.
- All the safety instructions in the Sunny Central installation guide must be observed.
- If the fault cannot be rectified with the help of this manual, contact SMA Solar Technology immediately.

If a fault occurs during operation, the Sunny Central will shut down and the fault will be displayed by the Sunny Central Control.

If several faults or warnings are present, the Sunny Central Control displays the fault which has the highest priority. It alternates between the standard view and the fault message.

A fault appears in the display as follows:

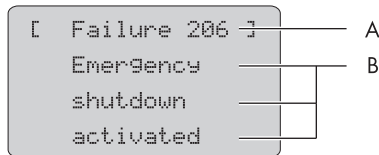

Marker	Description
A	Fault or warning number
B	Reason for the fault or warning in plain text



## 15.1 Fault Diagnosis

### 15.1.1 Categories of Faults and Warnings

The fault and warning numbers are allocated to different areas:

Number	Area
100 to 179	Grid faults
180 to 199	Grid warnings
200 to 279	Sunny Central hardware faults
280 to 299	Sunny Central hardware warnings
300 to 379	Sunny String-Monitor faults
380 to 399	Sunny String-Monitor warnings
400 to 479	Power unit hardware faults
480 to 499	Power unit hardware warnings
500 to 579	Team failures
280 to 599	Team warnings
600 to 699	External warnings

### 15.1.2 Types of Faults and Warnings

The Sunny Central faults and warnings are subdivided into four types:

Type	Description
Error type 1 (Warning)	The Sunny Central does not switch off. Once the error is no longer present, the error signal is reset automatically. Check the system.
Error type 2 (Fault)	The Sunny Central switches off. Once the error is no longer present, the error signal is reset automatically, and the Sunny Central starts up again.
Error type 3 (Fault)	The Sunny Central switches off. Error type 3 can only arise if the Sunny Central is in grid feed operation when an error occurs. Once the error is no longer present, the error signal is reset automatically, and the Sunny Central starts up again.
Error type 4 (Fault)	Error type 4 must be cleared before the Sunny Central can resume operation.  The Sunny Central switches off. Rectify the cause of the error, and clear the error at Sunny Central Control, or with Sunny Data Control. Once you have cleared the error, the Sunny Central resumes operation.

### 15.1.3 Warnings

No.	Description	
281	<p><b>Error text:</b> Ground fault or SPD defect</p>	Error type 1
<p><b>Cause of error:</b> The alert chain is interrupted (see wiring diagram).</p> <ul style="list-style-type: none"> <li>• Surge voltage protector damaged.</li> <li>• Back-up fuse(s) damaged on the grid side or generator side (if present).</li> <li>• The insulation resistance of the PV system is lower than the set threshold value.</li> <li>• The biasing circuit breaker of the transformer has tripped.</li> <li>• One of the redundant power supply units is defective.</li> </ul> <p><b>Corrective measures:</b></p> <ul style="list-style-type: none"> <li>• Check fault signaling of the surge voltage protectors and replace them if necessary.</li> <li>• Check protector back-up fuse(s), and replace if necessary.</li> <li>• Check PV system's insulation resistance.</li> <li>• In the event of an insulation fault, check strings under load-free conditions. Separate and connect individual strings to determine which string is faulty.</li> <li>• Check the function of the ground fault monitoring system.</li> <li>• Switch the biasing circuit breaker of the transformer back on.</li> <li>• Check the LEDs on the power supply unit and the monitoring module.</li> <li>• Contact Sunny Central Service.</li> </ul>		
283	<p><b>Error text:</b> cabinet Temp.</p>	Error type 1
<p><b>Cause of error:</b> The threshold value (parameter TMin or TMax) for the permissible cabinet temperature has been breached (too high or too low).</p> <p><b>Corrective measures:</b></p> <ul style="list-style-type: none"> <li>• Check function of cabinet cooling fans.</li> <li>• Clean or replace clogged air filters.</li> <li>• Check ambient temperature, and adjust it if necessary.</li> </ul>		
284	<p><b>Error text:</b> Temperature sensor</p>	Error type 1
<p><b>Cause of error:</b> External or internal temperature sensor is defective.</p> <p><b>Corrective measure:</b></p> <ul style="list-style-type: none"> <li>• Check sensors.</li> </ul>		

No.	Description	
380	<b>Error text:</b> SMU	<b>Error type 1</b>
<b>Cause of error:</b> The string monitoring system has detected one or more faulty strings or surge voltage protectors.  <b>Corrective measures:</b> <ul style="list-style-type: none"> <li>• Under "Device Set-up &gt; SMUs &gt; Devices &gt; Measured Values", read out the individual string currents to locate the faulty string.</li> <li>• More detailed information can be found in the Sunny String-Monitor manual.</li> </ul>		
381	<b>Error text:</b> ser. com. with SMU disturbed	<b>Error type 1</b>
<b>Cause of error:</b> Communication failure between Sunny Central and the Sunny String-Monitors.  <b>Corrective measures:</b> <ul style="list-style-type: none"> <li>• Check communication lines and connections.</li> <li>• More detailed information can be found in the Sunny String-Monitor manual.</li> </ul>		
382	<b>Error text:</b> thievery solar panel	<b>Error type 1</b>
<b>Cause of error:</b> Signal loop for theft detection at the Sunny String-Monitor has been interrupted.  <b>Corrective measures:</b> <ul style="list-style-type: none"> <li>• Check string currents.</li> <li>• Check signal loop.</li> <li>• For further details, refer to the installation guide and user manual of the Sunny String-Monitor and / or Sunny String-Monitor Cabinet.</li> </ul>		
585	<b>Error text:</b> ser. com. with team disturbed	<b>Error type 1</b>
<b>Cause of error:</b> The communication between the two team inverters has failed.  <b>Corrective measures:</b> <ul style="list-style-type: none"> <li>• Check the RS485 wiring for team communication.</li> <li>• Check power supply of the team member.</li> <li>• Check team parameters at both Sunny Centrals.</li> </ul>		

No.	Description	
586	<b>Error text:</b> Team contactor remain opened	Error type 1
	<b>Cause of error:</b> The team contactor does not trigger.  <b>Corrective measures:</b> <ul style="list-style-type: none"> <li>• Check the triggering of the team contactor.</li> <li>• Check the feedback contact of the isolation contactor.</li> <li>• Check whether the team current monitoring system has tripped.</li> </ul>	
587	<b>Error text:</b> Team contactor remain closed	Error type 1
	<b>Cause of error:</b> The team contactor has not switched off. The switching contacts may have got stuck.  <b>Corrective measures:</b> <ul style="list-style-type: none"> <li>• Check the triggering of the team contactor.</li> <li>• Check the contact position of the team contactor.</li> <li>• Contact Sunny Central Service.</li> </ul>	
588	<b>Error text:</b> Team contactor was opened	Error type 1
	<b>Cause of error:</b> The team contactor has been switched off by the team current monitoring system.  <b>Corrective measures:</b> <ul style="list-style-type: none"> <li>• Check the triggering of the team contactor.</li> <li>• Check the team current monitoring system (settings, fault).</li> <li>• Check the team current; it may be too high due to asymmetrical current distribution.</li> <li>• Contact Sunny Central Service.</li> </ul>	
601	<b>Error text:</b> Defective default Effective power	Error type 1
	<b>Cause of error:</b> The current value at the analog input is not within the permissible range.  <b>Corrective measures:</b> <ul style="list-style-type: none"> <li>• Check the analog input.</li> </ul>	

No.	Description	
602	<p><b>Error text:</b> Defective default Reactive power</p> <p><b>Cause of error:</b> The current value at the analog input is not within the permissible range.</p> <p><b>Corrective measures:</b></p> <ul style="list-style-type: none"> <li>• Check the analog input.</li> </ul>	<b>Error type 1</b>
603	<p><b>Error text:</b> Disturbed communication Effective power</p> <p><b>Cause of error:</b> The setpoint signal at the communication level is faulty.</p> <p><b>Corrective measures:</b></p> <ul style="list-style-type: none"> <li>• Check the communication route.</li> </ul>	<b>Error type 1</b>
604	<p><b>Error text:</b> Disturbed communication Reactive power</p> <p><b>Cause of error:</b> The setpoint signal at the communication level is faulty.</p> <p><b>Corrective measures:</b></p> <ul style="list-style-type: none"> <li>• Check the communication route.</li> </ul>	<b>Error type 1</b>
680	<p><b>Error text:</b> External Alarm was initiated</p> <p><b>Cause of error:</b> Dependent on the monitored unit.</p> <p><b>Corrective measures:</b> Check the unit connected to the external alarm input.</p>	<b>Error type 1</b>
681	<p><b>Error text:</b> Reduction of effective power activated</p> <p><b>Description:</b> The Sunny Central is currently reducing active power by means of an external setpoint.</p>	<b>Error type 1</b>

### 15.1.4 Faults

No.	Description	
104	<b>Error text:</b> No Grid Synchronization	Error type 3
	<b>Cause of error:</b> Left-hand rotating field or internal device fault.  <b>Corrective measures:</b> <ul style="list-style-type: none"> <li>• Check (right-hand) rotating field.</li> <li>• Check whether all internal fuses are switched on.</li> <li>• Contact the SMA Serviceline.</li> </ul>	
105	<b>Error text:</b> Grid voltage to low	Error type 2
	<b>Cause of error:</b> Voltage on the AC side is below the permitted range.  <b>Corrective measures:</b> <ul style="list-style-type: none"> <li>• Check the grid connections.</li> <li>• Check grid stability.</li> </ul>	
106	<b>Error text:</b> Grid voltage to high	Error type 2
	<b>Cause of error:</b> Voltage on the AC side is above the permitted range.  <b>Corrective measures:</b> <ul style="list-style-type: none"> <li>• Check the grid connections.</li> <li>• Check grid stability.</li> </ul>	
110	<b>Error text:</b> UVW-Range	Error type 2
	<b>Cause of error:</b> Voltage on phase L1, L2, or L3 outside the permitted range.  <b>Corrective measures:</b> <ul style="list-style-type: none"> <li>• Check the grid connections.</li> <li>• Check grid stability.</li> </ul>	

No.	Description	
111	<b>Error text:</b> Grid frequency to high or to low	<b>Error type 2</b>
	<b>Cause of error:</b> Grid limits breached.  <b>Corrective measures:</b> <ul style="list-style-type: none"> <li>• Check the display of the grid monitoring relay.</li> <li>• Check the fuses in the load circuit.</li> </ul>	
112	<b>Error text:</b> External Grid Monitoring triggered	<b>Error type 2</b>
	<b>Cause of error:</b> Voltage or frequency on the AC side is outside the permitted range.  <b>Corrective measures:</b> <ul style="list-style-type: none"> <li>• Check the grid connections.</li> <li>• Check grid stability.</li> <li>• Check right-hand rotating field.</li> </ul>	
201	<b>Error text:</b> Ground fault or Overtemperature	<b>Error type 2</b>
	<b>Cause of error:</b> <ul style="list-style-type: none"> <li>• The overtemperature fault chain is interrupted (see wiring diagram).</li> <li>• Switch cabinet overtemperature</li> <li>• Transformer overtemperature</li> <li>• Diode overtemperature</li> <li>• The insulation resistance of the PV system is lower than the set threshold value.</li> <li>• GFDI tripped</li> </ul> <b>Corrective measures:</b> <ul style="list-style-type: none"> <li>• Check function of cooling fans.</li> <li>• Clean or replace clogged air filters.</li> <li>• Ambient or cooling air temperature too high.</li> <li>• Check insulation resistance of PV generator.</li> <li>• In the event of an insulation fault, separate and connect individual strings to detect the faulty one.</li> <li>• Check the function of the ground fault monitoring system.</li> <li>• Check GFDI (see additional documentation in the download area at <a href="http://www.SMA.de/en">www.SMA.de/en</a>).</li> </ul>	

No.	Description	
206	<b>Error text:</b> Emergency shutdown activated	<b>Error type 4</b>
	<b>Cause of error:</b> Inverter's own emergency shut-off has been pressed.  <b>Corrective measures:</b> Deactivate the emergency shut-off and clear the fault as described in Section 15.2 "Clearing Errors" (page 93).	
209	<b>Error text:</b> DC Short circuit	<b>Error type 4</b>
	<b>Cause of error:</b> An internal short circuit in the inverter has been detected on the DC side. The DC main switch has been switched off.  <b>Corrective measures:</b> <ul style="list-style-type: none"> <li>• Check the Sunny Central from the outside.</li> <li>• If possible, the Sunny Central should be externally isolated.</li> <li>• Contact the SMA Serviceline.</li> </ul>	
215	<b>Error text:</b> heat sink fan fault	<b>Error type 2</b>
	<b>Cause of error:</b> <ul style="list-style-type: none"> <li>• Motor overload switch for the fan(s) cooling the power module has tripped.</li> <li>• Overtemperature protection for the fan(s) cooling the power module has tripped.</li> <li>• Ambient or cooling air temperatures too high.</li> </ul> <b>Corrective measures:</b> <ul style="list-style-type: none"> <li>• Switch the motor overload switch back on.</li> <li>• Check function of cooling fans.</li> <li>• Clean soiled air inlet or heat sink.</li> <li>• If this error occurs frequently, contact the SMA Serviceline.</li> </ul>	



No.	Description	
217	<b>Error text:</b> DC CB tripped or door switch open	<b>Error type 2</b>
<b>Cause of error:</b> <ul style="list-style-type: none"> <li>• The cabinet door was opened during operation.</li> <li>• The DC circuit breaker has tripped due to an internal fault.</li> <li>• The reverse current monitoring system on the DC side has tripped.</li> </ul> <b>Corrective measures:</b> <ul style="list-style-type: none"> <li>• Close the cabinet doors.</li> <li>• Check the function of the door switches.</li> <li>• Check the function and activation of the emergency shut-off relay.</li> <li>• Check reverse current monitoring.</li> <li>• Contact the SMA Serviceline.</li> </ul>		
220	<b>Error text:</b> Release- or Reset-Signal faulty	<b>Error type 2</b>
<b>Cause of error:</b> The inverter bridge release or clearance signal is defective.		
<b>Corrective measures:</b> If this is a permanent error, please contact the SMA Serviceline.		
221	<b>Error text:</b> CHOPPER Overtemperature	<b>Error type 3</b>
<b>Cause of error:</b> <ul style="list-style-type: none"> <li>• EVR resistor overtemperature.</li> <li>• Defective chopper module.</li> <li>• After 90 minutes, the inverter will attempt to restart.</li> </ul> <b>Corrective measures:</b> <ul style="list-style-type: none"> <li>• Check resistor for dirt.</li> <li>• Make sure resistor is sufficiently ventilated.</li> <li>• Contact the SMA Serviceline.</li> </ul>		

No.	Description	
222	<b>Error text:</b> Ambient temperature	<b>Error type 2</b>
<b>Cause of error:</b> The ambient temperature is higher than 51 °C.  <b>Corrective measure:</b> <ul style="list-style-type: none"> <li>• Check the cooling concept.</li> <li>• Check the fans.</li> <li>• Check the ambient conditions.</li> <li>• Check the sensor.</li> </ul>		
400	<b>Error text:</b> internal failure of inverter bridge	<b>Error type 2/3</b>
<b>Cause of error:</b> Internal inverter bridge fault (e.g. symmetry fault, board voltage, undertemperature, sensor broken).  <b>Corrective measures:</b> If this error occurs frequently, contact the SMA Serviceline.		
402	<b>Error text:</b> ser. com. with inverter bridge disturbed	<b>Error type 2</b>
<b>Cause of error:</b> <ul style="list-style-type: none"> <li>• The RS485 communication between the inverter bridge and the Sunny Central Control is interrupted.</li> <li>• The inverter bridge or the Sunny Central Control may be faulty.</li> </ul> <b>Corrective measures:</b> <ul style="list-style-type: none"> <li>• Check the RS485 wiring.</li> <li>• If this is a permanent error, please contact the SMA Serviceline.</li> </ul>		
408	<b>Error text:</b> PV Overvoltage	<b>Error type 3</b>
<b>Cause of error:</b> DC voltage is too high on the generator side.  <b>Corrective measures:</b> <ul style="list-style-type: none"> <li>• Immediately disconnect the PV generator from the Sunny Central! Danger of damage to the Sunny Central!</li> <li>• Check DC voltage.</li> <li>• Check module wiring and system design.</li> </ul>		

No.	Description	
409	<b>Error text:</b> IGBT Stack Temperature	<b>Error type 3</b>
	<b>Cause of error:</b> Heat sink temperature is too high (software). <b>Corrective measures:</b> <ul style="list-style-type: none"> <li>• Check that the cooling fans of the inverter bridge are working properly.</li> <li>• Clean soiled air inlet or heat sink.</li> <li>• Ambient or cooling air temperature too high.</li> <li>• If this error occurs frequently, contact the SMA Serviceline.</li> </ul>	
410	<b>Error text:</b> IGBT Stack Error Sum	<b>Error type 3</b>
	<b>Cause of error:</b> Internal inverter bridge fault (e.g. DC overvoltage, overtemperature, defective driver, overcurrent). <b>Corrective measures:</b> If this error occurs frequently, contact the SMA Serviceline.	
411	<b>Error text:</b> IGBT-Overcurrent or UVW-Phase Error ADAPSCP	<b>Error type 3</b>
	<b>Cause of error:</b> Internal inverter bridge fault. <b>Corrective measures:</b> If this error occurs frequently, contact the SMA Serviceline.	
412	<b>Error text:</b> Overcurrent	<b>Error type 3</b>
	<b>Cause of error:</b> Internal inverter bridge fault. <b>Corrective measures:</b> If this error occurs frequently, contact the SMA Serviceline.	

No.	Description	
420	<p><b>Error text:</b> ADAPSCP Overtemperature</p> <p><b>Cause of error:</b> Heat sink temperature is too high (hardware threshold)</p> <p><b>Corrective measures:</b></p> <ul style="list-style-type: none"> <li>• Check that the cooling fans of the inverter bridge are working properly.</li> <li>• Clean soiled air inlet or heat sink.</li> <li>• Ambient or cooling air temperature too high.</li> <li>• If this error occurs frequently, contact the SMA Serviceline.</li> </ul>	<b>Error type 3</b>
421	<p><b>Error text:</b> ADAPSCP Overvoltage DC Voltage link</p> <p><b>Cause of error:</b> DC voltage is too high on the generator side (hardware threshold).</p> <p><b>Corrective measures:</b></p> <ul style="list-style-type: none"> <li>• Immediately disconnect the PV generator from the Sunny Central! Danger of damage to the Sunny Central!</li> <li>• Check DC voltage.</li> <li>• Check module wiring and system design.</li> </ul>	<b>Error type 2</b>

### 15.1.5 Events

Event	Explanation
> LVRT	LVRT (Low Voltage Ride Through) is activated
> Netz-Parameter	Adjusting the grid parameters
> NSM	Power limitation via NSM (grid security management) activated
< NSM	Power limitation via NSM (grid security management) deactivated
> FRQ-Derating	Power limitation via frequency activated
< FRQ-Derating	Power limitation via frequency deactivated

### 15.2 Clearing Errors

1. Rectify the cause of the error.
2. Select "Operating data > Faults > Current Faults".

```
[   Faults   ]
→Current Faults
-----
```



**Active fault or warning**

If a fault or warning is present, it is displayed with the date and time of its occurrence.

3. Press [ENTER].
  - The display begins to blink.
4. Press [ ↓ ] once.
  - The word "quit" appears in the display.
5. To quit the error, press [ENTER] twice.
  - The error is now cleared. The message shown on the right appears in the display.

```
[ Actual Faults]
Quit-Function
→.....---
no Failure
```

## 16 Contact

If you have technical problems concerning our products, please contact the SMA Serviceline.

We require the following information in order to provide you with the necessary assistance:

- Type of Sunny Central
- Sunny Central serial number
- Type and number of the connected modules
- Communication type
- Fault or warning number displayed
- Display message in Sunny Central Control

### **SMA Solar Technology AG**

Sonnenallee 1

34266 Niestetal, Germany

Tel. +49 561 9522 299

Fax +49 561 9522 3299

SunnyCentral.Service@SMA.de

www.SMA.de

The information contained in this document is the property of SMA Solar Technology AG. Publishing its content, either partially or in full, requires the written permission of SMA Solar Technology AG. Any internal company copying of the document for the purposes of evaluating the product or its correct implementation is allowed and does not require permission.

## Exclusion of liability

The general terms and conditions of delivery of SMA Solar Technology AG shall apply.

The content of these documents is continually checked and amended, where necessary. However, discrepancies cannot be excluded. No guarantee is made for the completeness of these documents. The latest version is available online at [www.SMA.de](http://www.SMA.de) or from the usual sales channels.

Guarantee or liability claims for damages of any kind are excluded if they are caused by one or more of the following:

- Damages during transportation
- Improper or inappropriate use of the product
- Operating the product in an unintended environment
- Operating the product whilst ignoring relevant, statutory safety regulations in the deployment location
- Ignoring safety warnings and instructions contained in all documents relevant to the product
- Operating the product under incorrect safety or protection conditions
- Altering the product or supplied software without authority
- The product malfunctions due to operating attached or neighboring devices beyond statutory limit values
- In case of unforeseen calamity or force majeure

The use of supplied software produced by SMA Solar Technology AG is subject to the following conditions:

- SMA Solar Technology AG rejects any liability for direct or indirect damages arising from the use of software developed by SMA Solar Technology AG. This also applies to the provision or non-provision of support activities.
- Supplied software not developed by SMA Solar Technology AG is subject to the respective licensing and liability agreements of the manufacturer.

## SMA Factory Warranty

The current guarantee conditions come enclosed with your device. These are also available online at [www.SMA.de](http://www.SMA.de) and can be downloaded or are available on paper from the usual sales channels if required.

## Trademarks

All trademarks are recognized even if these are not marked separately. Missing designations do not mean that a product or brand is not a registered trademark.

The *Bluetooth*<sup>®</sup> word mark and logos are registered trademarks owned by Bluetooth SIG, Inc. and any use of such marks by SMA Solar Technology is under license.

### SMA Solar Technology AG

Sonnenallee 1

34266 Niestetal

Germany

Tel. +49 561 9522-0

Fax +49 561 9522-100

[www.SMA.de](http://www.SMA.de)

E-Mail: [info@SMA.de](mailto:info@SMA.de)

© 2004 to 2010 SMA Solar Technology AG. All rights reserved

SMA Solar Technology AG

[www.SMA.de](http://www.SMA.de)

